

MATRIX

ROWER-02





matrixfitness.com/manuals

ENG	To download the latest owner's manual, in the language of your choice, visit the website above. For further assistance, Matrix contact information is on the next page.
GER	Das neueste Benutzerhandbuch in der Sprache Ihrer Wahl können Sie auf der zuvor genannten Website herunterladen. Falls Sie weitere Hilfe benötigen, finden Sie die Matrix-Kontaktinformationen auf der nächsten Seite.
FRE	Pour télécharger la version la plus récente du guide d'utilisation dans la langue de votre choix, visitez le site ci-dessus. Si vous avez besoin d'aide, rendez-vous sur la page suivante pour obtenir les coordonnées de Matrix.
SPE	Para descargar el último manual de usuario en el idioma que prefiera, visite el sitio web anterior. Si necesita más ayuda, la información de contacto de Matrix se encuentra en la página siguiente.
DUT	Ga naar de bovenstaande website om de laatste gebruikershandleiding te downloaden in de taal van uw keuze. Voor extra hulp vindt u de Matrix-contactgegevens op de volgende pagina.
DAN	Du kan downloade den seneste brugsvejledning på dit foretrukne sprog fra webstedet ovenfor. Hvis du har brug for yderligere hjælp, henvises du til Matrix' kontaktoplysninger på næste side.
ITA	Per scaricare il più recente manuale del proprietario, nella lingua che preferisci, visita il sito Web indicato in precedenza. Per ulteriore assistenza, le informazioni di contatto per Matrix si trovano alla pagina successiva.
GRK	Για λήψη του πιο πρόσφατου εγχειριδίου χρήστη, στη γλώσσα της επιλογής σας, επισκεφθείτε την παραπάνω ιστοσελίδα. Για περαιτέρω βοήθεια, πληροφορίες επικοινωνίας με την Matrix παρέχονται στην επόμενη σελίδα.
POL	Aby pobrać najaktualniejszą wersję instrukcji obsługi w wybranym języku, należy odwiedzić powyższą stronę internetową. Jeśli potrzebna jest dalsza pomoc, można skorzystać z informacji kontaktowych Matrix podanych na kolejnej stronie.
PRB	Para baixar a versão mais recente do nosso manual em seu idioma, acesse o site acima. Para obter mais assistência, as informações de contato da Matrix estão na próxima página.
CHT	若要下載您所選語言版本的最新使用手冊，請造訪上述網站。如需其他協助，請參閱下一頁的 Matrix 聯絡資訊。
JPN	ご希望の言語版の最新オーナーズマニュアルは、上記ウェブサイトからダウンロードしてください。さらにサポートが必要な場合は、次ページに記載されているMatrixお問い合わせ窓口までご連絡ください。
KOR	선택한 언어로 최신 사용설명서를 다운로드하려면 위의 웹 사이트를 참조하십시오. 추가 지원이 필요한 경우 다음 페이지에 있는 Matrix 연락처 정보로 요청하십시오.
VTM	Để tải về sách hướng dẫn sử dụng mới nhất, bằng ngôn ngữ của bạn, hãy truy cập trang web bên trên. Để được trợ giúp thêm, thông tin liên lạc của Matrix có ở trang kế tiếp.
THI	ท่านสามารถดาวน์โหลดคู่มือผู้ใช้ล่าสุดในภาษาที่ต้องการได้จากเว็บไซต์ข้างต้น หากท่านต้องการความช่วยเหลืออื่น ๆ โปรดติดต่อไปยังข้อมูลติดต่อ Matrix ที่ให้ไว้ในหน้าถัดไป
ARB	هالعال ببول عقوم ةدرايزب لصففت ،اهاراتخت يتال ةغللاب ،كلاملل ليلد ةدحأ ليزنتل .ةلالال ةحفصلل في Matrix ةكرشب ةصاخلل لاصللال ةامولعلم ةجوت ،ةءءاسملل نم ةيزمل



AUSTRALIA
Johnson Health Tech Australia
6B Hazelwood Drive
Morwell
VIC 3840 AUSTRALIA
Tel: +61 1300 760 601
au.matrixfitness.com

BRAZIL
Johnson Health Tech Brasil
Estrada Municipal, 200 - mód 14 e 15 - gleba 3
Chácara Alvorada
Indaiatuba, SP
CEP 13337-200 BRASIL
Tel: +55-19-2107-5300
br.matrixfitness.com

CANADA
Johnson Health Tech Canada
10401, Ray-Lawson Blvd.
Montreal, Quebec H1J 1M3
CANADA
Tel: 514-336-0006
www.matrixfitness.com

CHINA
Johnson Health Tech (Shanghai) Co., Ltd.
Rm 508-512
HuaWen Plaza 999 Zhongshan
(West) Road
Changning District
Shanghai, 200050 CHINA
Tel: +86-021-32503800
www.johnsonfitness.com.cn

FRANCE
Johnson Health Tech France
45, avenue Georges Politzer
Trappes
78190 FRANCE
Tel: +33 01 30 68 62 80
www.matrixfitness.fr

GERMANY / AUSTRIA
Johnson Health Tech. GmbH
Nikolaus-Otto-Str. 1
D-22946 Trittau GERMANY
Tel. +49 (0)4154-7952-0
www.matrixfitness.eu

GREECE
Johnson Health Tech Hellas SA
12 Vas. Konstantinou Avenue
116 35 Athens GREECE
Tel: +20 211 4112797
www.Johnson Health Tech.gr

HONG KONG
Johnson Health Tech (HK) Limited
Room 1501-1502, Aitken Vanson Centre,
61 Hoi Yuen Road, Kwun Tong
Kowloon
HONG KONG
Tel: +852-2302 0596
hk.matrixfitness.com

IBERIAN PENINSULA (SPAIN, PORTUGAL)
Johnson Health Tech Ibérica
Avenida de la Astronomía, 4 nave 9.2
San Fernando de Henares
28830 Madrid - ESPAÑA
Tel: +34-91 6293 688
www.matrixfitness.es

ITALY
Johnson Health Tech Italia Spa
Zona Ind.le Campolungo 11
63100 Ascoli Piceno (AP)
ITALY
Tel: +39 0736 22699
www.matrixfitness.it

JAPAN
Johnson Health Tech Japan
Yasuda Bldg. 2F,
3-3-8 Kaigan,
Minato-ku Tokyo 108-8435
JAPAN
Tel: +81-3-5419-3560
www.matrixfitness.jp

KOREA
Johnson Health Tech Co., Ltd. Korea Branch
203 ho, A-Block Richensia Young
San133-3 Wonhyoro 1-ga, Young San
Gu, 140-111 Seoul
SOUTH KOREA
Tel: +82-2-6731-0175
kr.matrixfitness.com

MALAYSIA
Johnson Fitness (Malaysia) Sdn. Bhd.
Lot 557D, Jalan Subang 3
Subang Jaya Industrial Estate
47610 Subang Jaya
Selangor MALAYSIA
Tel: +60-603-5632 8273
my.matrixfitness.com

NETHERLANDS (BELGIUM, DENMARK, LUXEMBOURG)
Matrix Fitness / Johnson Health Tech. Netherlands
Vleugelboot 14
3991 CL Houten
NETHERLANDS
Tel: +31 30 24 45 435
www.matrixfitness.nl

PHILIPPINES
Johnson Health Tech. Commercial Philippines Inc.
15th Floor, Citibank Center, 8741 Paseo de Roxas,
Makati City, Metro Manila, 1226 PHILIPPINES
Tel: +63-2-558-6590
world.matrixfitness.com

POLAND
Johnson Health Tech Poland
ul. Działkowa 62
02-234 Warszawa POLAND
Tel: +49 2234 9997-100
pl.matrixfitness.com

SWITZERLAND
Johnson Health Tech. (Schweiz) GmbH
Althardstrasse 185
CH-8105 Regensdorf SWITZERLAND
Tel. +41 (0)44-843 30 30
www.matrixfitness.ch

TAIWAN
Johnson Health Tech Taiwan
999, Sec 2, Dongda Rd., Daya Dist.,
Taichung City 428
TAIWAN (R.O.C)
Tel: +886-4-25667100
world.matrixfitness.com/zh

THAILAND
Johnson Health Tech Thailand
9th Floor, Unit 9B, Bangna Towers,
Tower A 2/3
Moo 14, Bangna-Trad Rd.
K.M. 6.5 Bangkaew, Pangplee
Samutprakan, 10540 THAILAND
Tel: +66-2751-9360
th.matrixfitness.com

UNITED ARAB EMIRATES
Johnson Health Tech. UAE
ICON Tower, Office #602
TECOM, Al Barsha
Dubai, United Arab Emirates
Tel: +971 4 4567939
world.matrixfitness.com/

UNITED KINGDOM
(ENGLAND, SCOTLAND, N. IRELAND, WALES)
Johnson Health Tech UK
Riverside park
Campbell Road
Stoke on Trent
ST4 4EY ENGLAND
Tel: +44-1782644900
www.matrixfitness.co.uk

UNITED STATES
Matrix Fitness / Johnson Health Tech NA
1600 Landmark Drive
Cottage Grove, WI 53527 USA
Toll Free: +1-866-693-4863
www.matrixfitness.com

VIETNAM
Johnson Health Tech (Vietnam) Co. Ltd.
Unit 2302, Lim Tower
9-11 Ton Duc Thang Street
Ben Nghe Ward, District 1
Ho Chi Minh City
VIETNAM
Tel: +84 909 977957
vn.matrixfitness.com

INTERNATIONAL (OTHER COUNTRIES)
Matrix Fitness International
999, Sec 2, Dongda Rd., Daya Dist.,
Taichung City 428
TAIWAN (R.O.C)
Tel: +886-4-25667100
world.matrixfitness.com



IMPORTANT INSTRUCTIONS

It is the sole responsibility of the purchaser of Matrix Fitness Systems products to instruct all individuals, whether they are the end user or supervising personnel, on proper usage of the equipment. See “Product Specifications” (next page) for product specific features. The Matrix Rower is intended for commercial use.

It is recommended that all users of Matrix Fitness exercise equipment should be informed of the following information prior to its use.

When using the Matrix Rower, always follow basic precautions:

- To ensure your safety and to protect the unit, read all the instructions before assembling and using the Rower.
- To ensure the proper use and safety of the Rower, make sure that all users read this manual. Please make this manual a part of your facility's training program. Remind the users that before undertaking any fitness program, they should obtain complete physical examinations from their physicians. If, at any time while exercising, the user experiences dizziness, pain, or shortness of breath, nausea or feels faint he or she must stop immediately.

READ AND SAVE THESE INSTRUCTIONS

This Rower is intended for commercial use. To ensure your safety and protect the equipment, read all instructions before operating the MATRIX Rower.

- Use the Rower for its intended purpose as described in this manual. Do not use attachments that have not been recommended by the manufacturer.
- Never drop or insert any object into any opening in the product. If an object should drop inside, carefully retrieve it while the unit is not in use. If the item cannot be reached, contact Matrix Fitness or authorized dealers.
- Never operate the Rower if it is not working properly, or if it has been damaged or immersed in water. Return it to Matrix Fitness or authorized dealers for examination and repair.
- Keep hands and feet clear at all times from moving parts to avoid injury.
- Do not reach into, or underneath the unit, and do not tip the unit on its side during operation.
- Do not use the Matrix Rower outdoors, near swimming pools or in areas of high humidity.
- Do not operate where aerosol (spray) products are being used or when oxygen is being administered.
- Do not remove the side shrouds. Service should only be done by an authorized service technician.
- Close supervision is necessary when used near children, invalids or disabled people.
- When the Rower is in use, young children and pets should be kept at least three meters / ten feet away.
- Assemble and operate the unit on a solid, level surface. Place the unit at least one meter / three feet of clearance from any obstructions, including walls and furniture.
- Do not wear any clothing that might catch on any moving parts of this Rower.
- Place handle in hooks before letting go.
- Do not let handle fly into console bracket.
- Perform proper maintenance as described in the Maintenance section of this manual.

CAUTION: If you experience chest pain, nausea, dizziness or shortness of breath, STOP exercising immediately and consult a physician before continuing.

CAUTION: Any changes or modifications to this equipment could void the product warranty.

GETTING STARTED

Read the Owner's Manual before setting up the Matrix Rower. Place the unit where it will be used before beginning the setup procedure.

CHOOSING A LOCATION

The site should be well-lit and well-ventilated. Place the Rower on a structurally solid flat surface and kept a few feet from the wall or any equipment. If the site has a heavy plush carpet, to protect the carpeting and machinery, you should place a rigid plastic base under the unit.

Please do not place the Rower in an area of high humidity, such as the vicinity of a steam room, indoor pool, or sauna. Exposure to intensive water vapour or chlorine could adversely affect the electronics, as well as other parts of the machine.

BEFORE YOUR FIRST ROW

- Consult your physician. Be sure that it is not dangerous for you to undertake a strenuous exercise program.
- Improper technique such as extreme layback or jumping off the seat can result in injury.
- Start each workout with several minutes of easy rowing for a warm-up.
- Start your exercise program gradually. Row no more than 5 minutes the first day to let your body adjust to the new exercise.
- Gradually increase your rowing time and intensity over the first two weeks. Do not row at full power until you are comfortable with the technique and have rowed for at least a week. Like any physical activity, if you increase the volume and intensity too rapidly, fail to warm up properly, or use poor technique, you will increase the risk of injury.
- The best resistance setting for a great cardiovascular workout is in the range of 3-5. Rowing with the resistance setting too high can be detrimental to your training program because it may reduce your output and increase your risk of injury.
- Aim for a stroke rate (spm) of between 24 and 30 spm (strokes per minute).



MAINTENANCE

1. DO NOT use any equipment that is damaged and or has worn or broken parts. Use only replacement parts supplied by your country's local MATRIX dealer.
2. MAINTAIN LABELS AND NAMEPLATES: Do not remove labels for any reason. They contain important information. If unreadable or missing, contact your MATRIX dealer for a replacement.
3. MAINTAIN ALL EQUIPMENT: Preventative maintenance is the key to smooth operating equipment as well as keeping your liability to a minimum. Equipment needs to be inspected at regular intervals.
4. Ensure that any person(s) making adjustments or performing maintenance or repair of any kind is qualified to do so. MATRIX dealers will provide service and maintenance training at our corporate facility upon request.

WARRANTY

For North America, please visit www.matrixfitness.com for warranty information along with warranty exclusions and limitations.

SERIAL NUMBER LOCATION

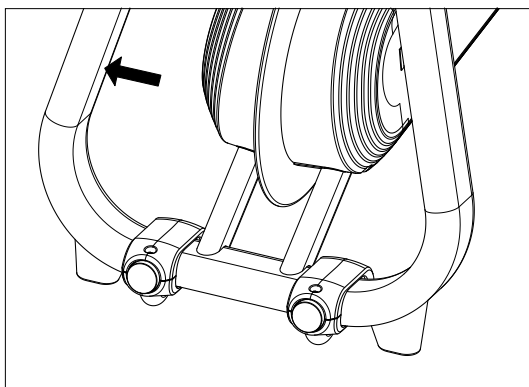

DAILY MAINTENANCE

Look and listen for loose fasteners, unusual noises, and any other indications that the equipment may be in need of service. If you notice any of these, obtain service.

Matrix Fitness recommends the Rower be cleaned before and after each workout. The following daily maintenance tips will keep your unit operating at peak performance:

1. Use a damp, soft cloth with water or mild liquid detergent to clean all exposed surfaces. DO NOT use ammonia, chlorine, or acid-based cleaners.
2. Keep the display console free of fingerprints and salt build-up caused by sweat.
3. Frequently vacuum the floor underneath the unit to prevent the accumulation of dust and dirt, which can affect the smooth operation of the unit.
4. Check for dust inside flywheel with flashlight.

PRODUCT SPECIFICATIONS

CONSOLE	
Display Screen	Extra-large LCD display
Display Readout	Time, Distance, SPM (strokes per minute), Stroke, Watts, Heart Rate, Calories, 500 mtr/split
Programs	Manual, Interval, Challenge
Telemetric Receiver	Yes
TECHNICAL DATA	
Resistance Technology	Magnetic resistance
Resistance Levels	10
Drive System	Coil spring poly-V belt
Max User Weight	160 kg / 350 lbs
Product Weight	59 kg / 130 lbs
Shipping Weight	69 kg / 152 lbs
Overall Dimensions (L x W x H)*	223 x 55 x 58 cm / 87.6" x 21.5" x 22.7"
Power Requirement	Battery powered for LCD display
SPECIAL FEATURES	
Handlebar Design	Extra-long ergo-grip handlebar
Foot Stretchers	Adjustable heel cups with easy-to-read settings
Monorail	Aluminum

* Ensure a minimum clearance width of 0.6 meters (24") for access to and passage around MATRIX equipment. Please note, 0.91 meters (36") is the ADA recommended clearance width for individuals in wheelchairs. Product specifications are subject to change without notice.

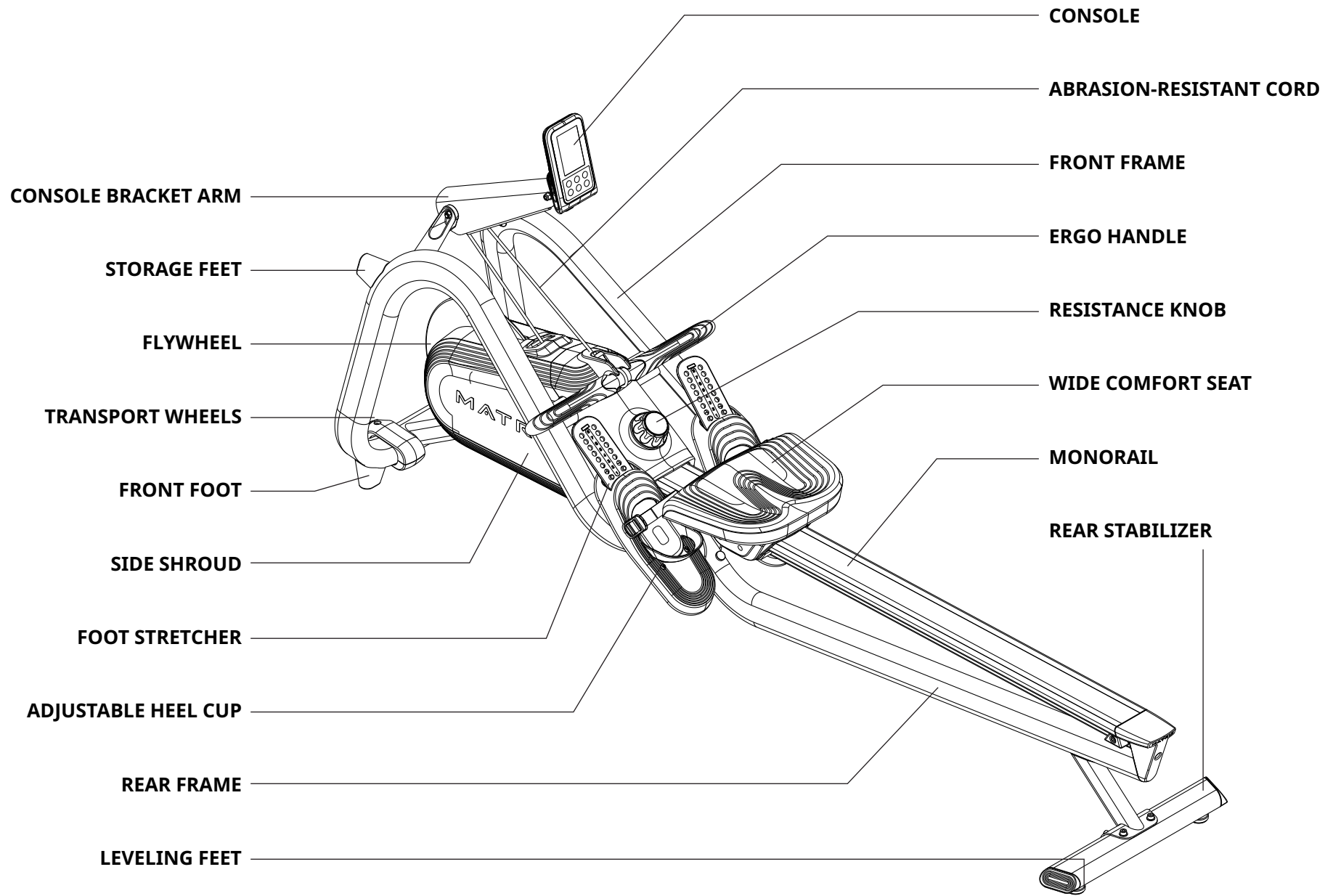



UNPACKING

Thank you for purchasing a MATRIX Fitness product. It is inspected before it is packaged. It is shipped in multiple pieces to facilitate the compact packaging of the machine. Prior to assembly, confirm all the components by matching them with the exploded diagrams. Carefully unpack the unit from this box and dispose of the packing materials in accordance with your local laws.

CAUTION

To avoid injury to yourself and prevent damage to the frame components, be sure to have proper assistance removing the frame pieces from this box.

ROWER LOCATION

Place the equipment on a level and stable surface away from direct sunlight. The intense UV light can cause discoloration on the plastics. Locate your equipment in an area with cool temperatures and low humidity. Ensure a minimum clearance width of 0.6 meters (24") for access to and passage around MATRIX equipment. Please note, 0.91 meters (36") is the ADA recommended clearance width for individuals in wheelchairs. Do not place the equipment in any area that will block any vent or air openings. The equipment should not be located in a garage, covered patio, near water or outdoors.

Store the vertical unit on a solid and level surface.

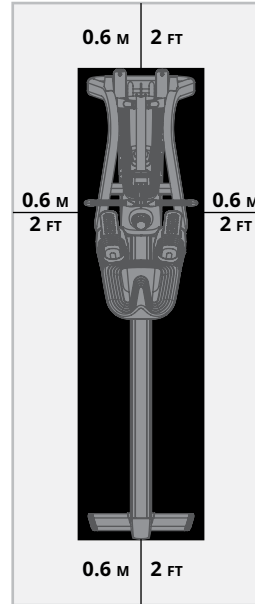

STORAGE

CAUTION

Caution should be used when storing rowers in an upright storage position. Rowers have been tested for stability when stored in an upright storage position. While testing has shown that the rowers can maintain their stability when tilted up to 10 degrees, accidental contact with an upright rower may potentially knock over the rower.

- Care should be used when handling rowers in the upright storage position.
- Any rower stored in the upright storage position shall be stored in a protected area to prevent accidental contact with the rower.
- Unless people are storing a rower or retrieving a rower from storage, keep people away from upright stored rowers.

TOOLS REQUIRED FOR ASSEMBLY (not included)

4MM L-Shaped Allen Wrench



5MM L-Shaped Allen Wrench



6MM L-Shaped Allen Wrench



8MM L-Shaped Allen Wrench



Phillips Screwdriver



13MM Open-End Wrench



14MM Open-End Wrench



17MM Open-End Wrench

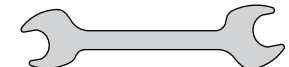

If any items are missing please contact your country's local MATRIX dealer for assistance.

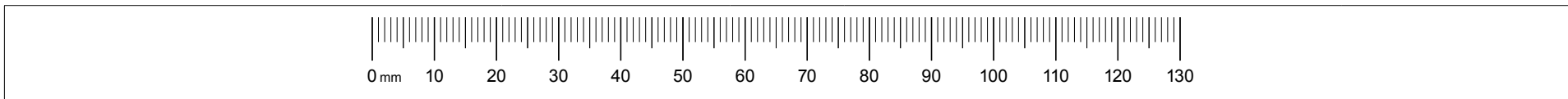

**1****Black Hardware Pack**

Description	Qty
A Bolt	2

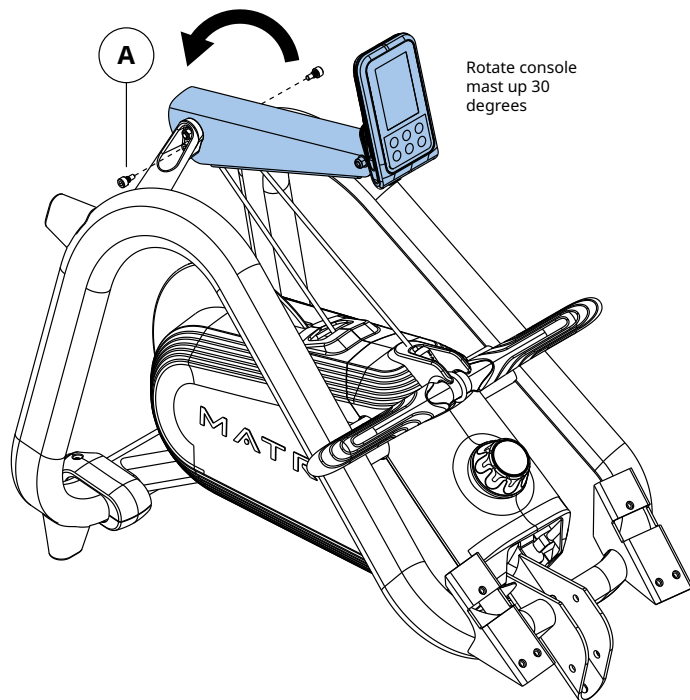
**2****Orange Hardware Pack**

Description	Qty
B Flat Washer	2
C Bolt	4
D Arc Washer	2

Note:

Tighten hardware from step 2 using the Torque Value:
24.5 Nm / 18 ft-lb

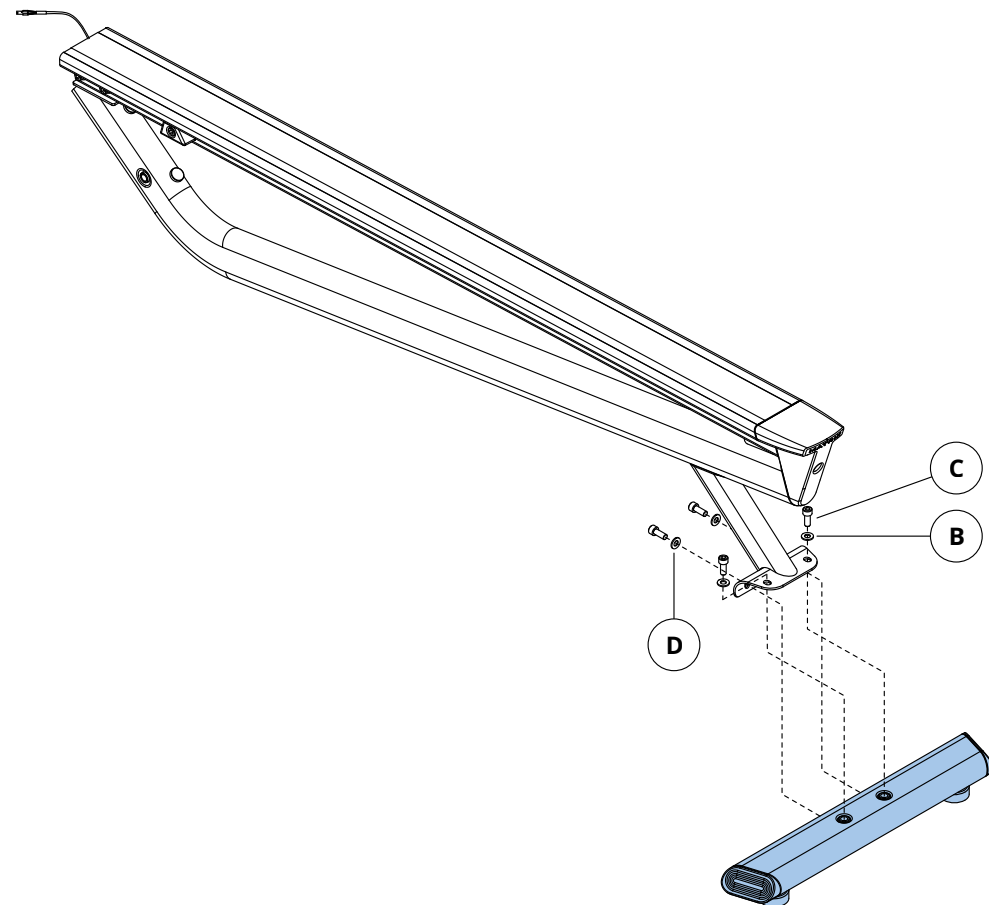

3

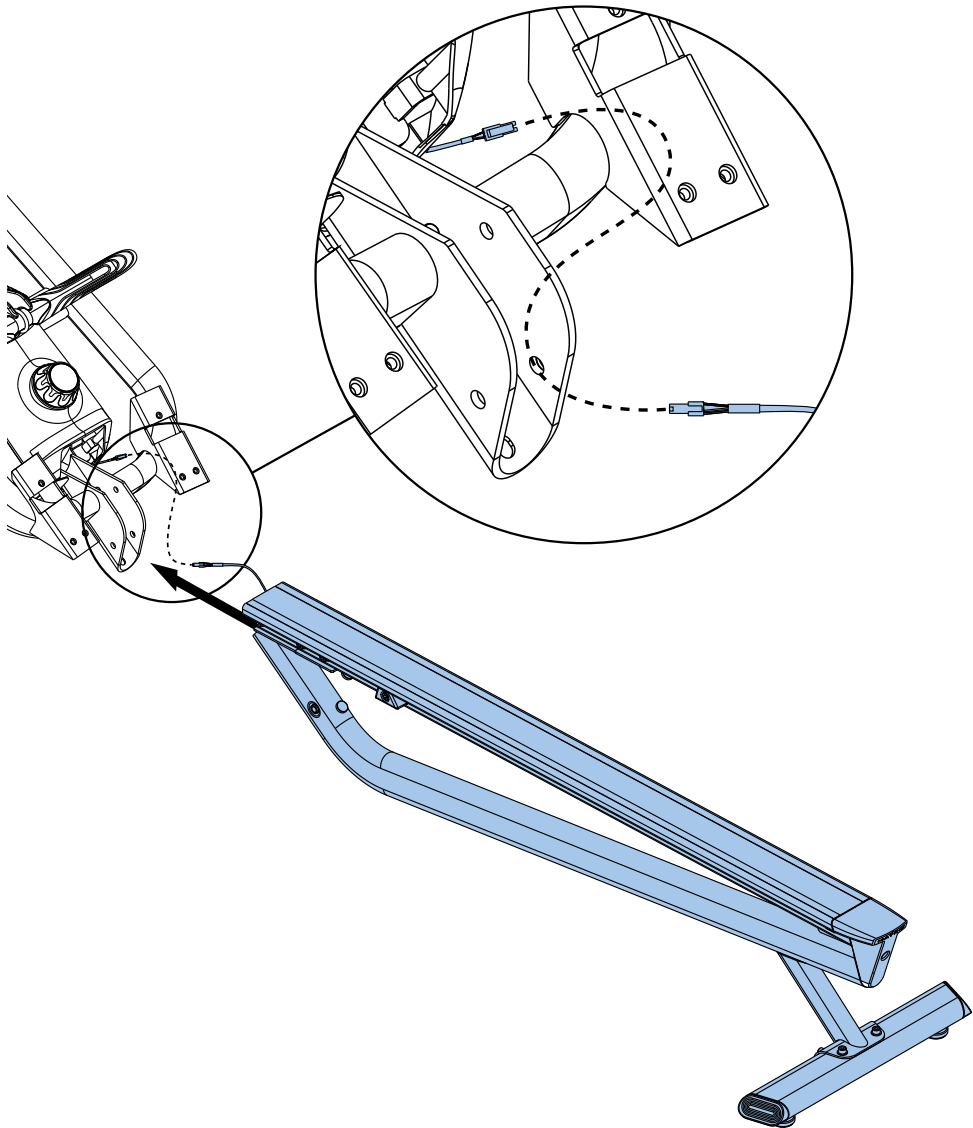

4

Red Hardware Pack

Description	Qty
E Bolt	3
F Flat Washer	2
G Nut	1
H Arc Washer	2

Note:

Tighten hardware from step 4 using the Torque Value: 39.2 Nm / 29 ft-lb

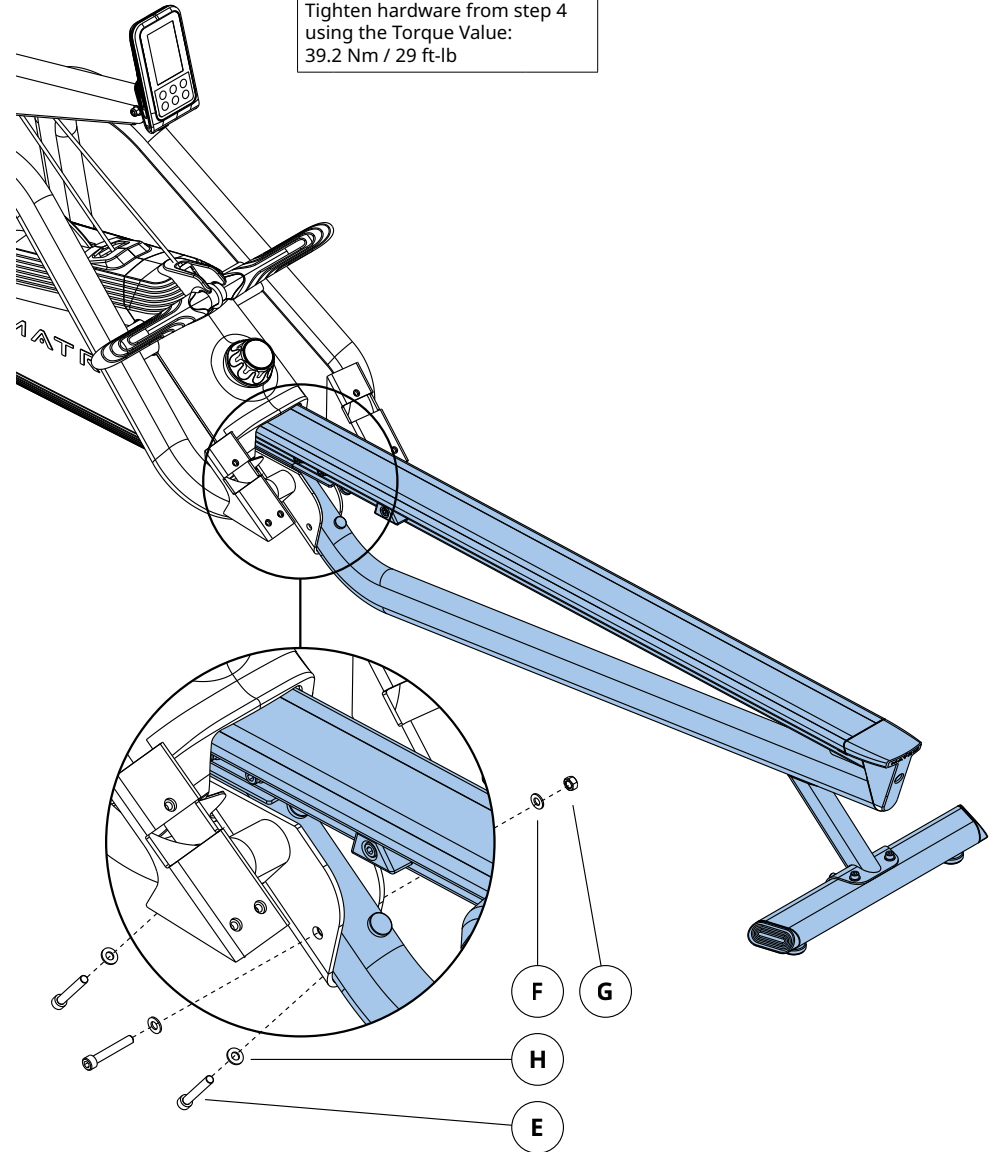

**5****White Hardware Pack**

Description	Qty
I Bolt	6

Note:

Tighten hardware from step 5 using the Torque Value:
24.5 Nm / 18 ft-lb

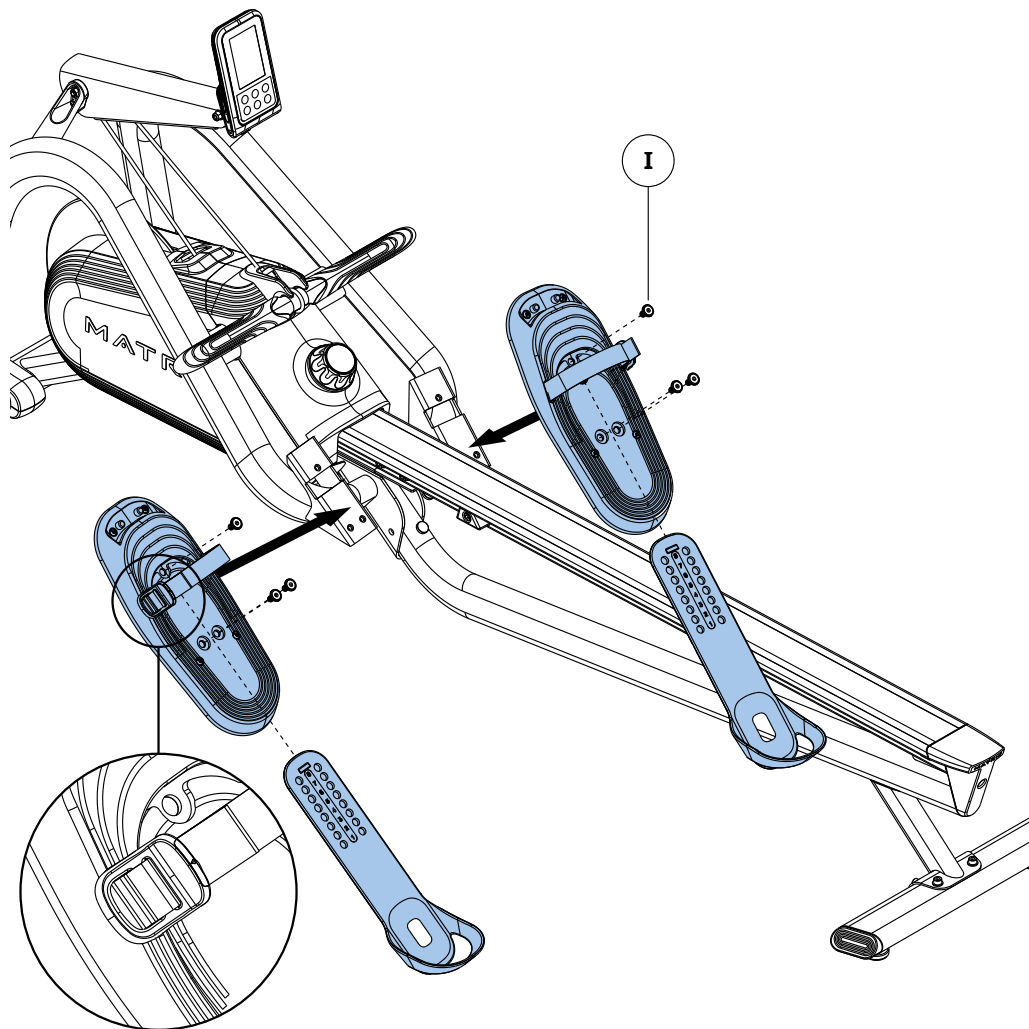
**6****Pre-installed Hardware**

Description	Qty
J Flat Washer	2
K Stopper Left	1
L Stopper Right	1
M Bushing	2
N Bolt	2

Note:

Tighten hardware from step 6 using the Torque Value:
24.5 Nm / 18 ft-lb

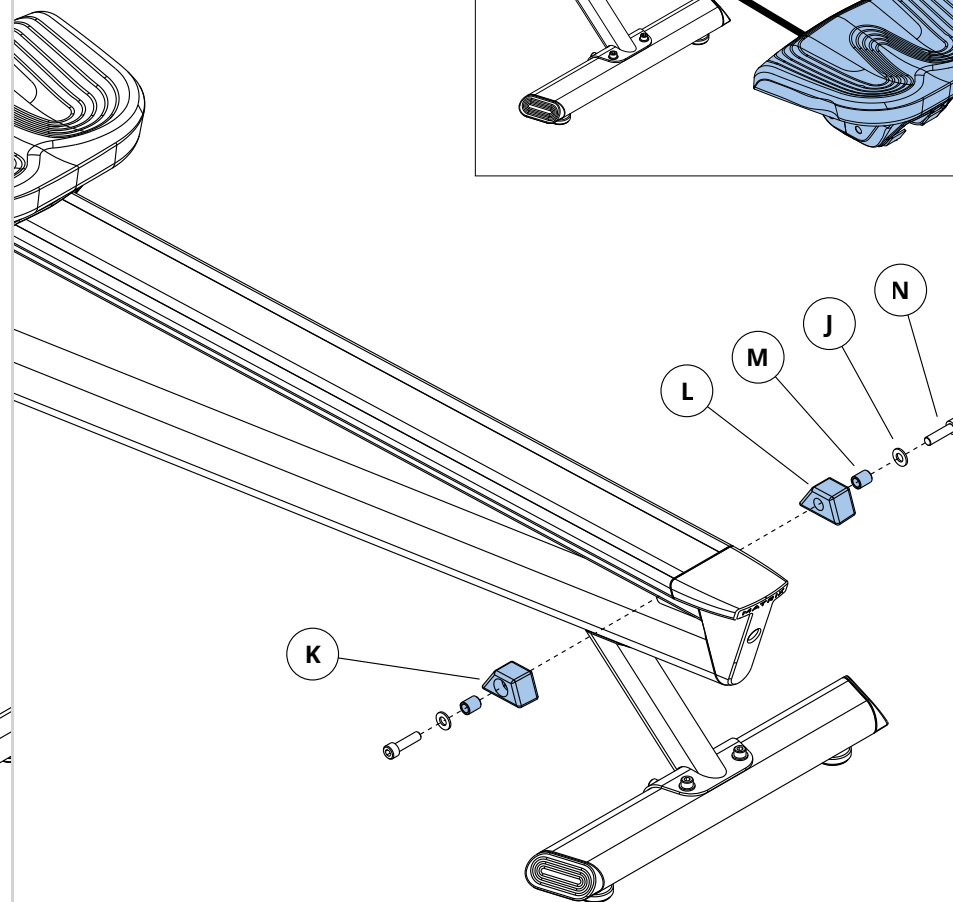
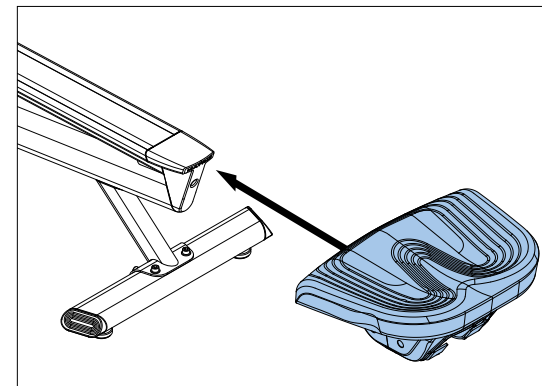
**ASSEMBLY COMPLETE!**



MATRIX

150 W

▶ 03:21

1234 m 21:26

2:37/500m 32spm

--- ♥ --- cal

BACKLIT LCD

Displays Watts, Time, Distance, 500 m/split, SPM, Heart Rate and Calories (When heart rate strap is worn)

DISTANCE QUICK KEY

TIME QUICK KEY

MENU

NAVIGATION ARROWS

CONFIRMATION KEY

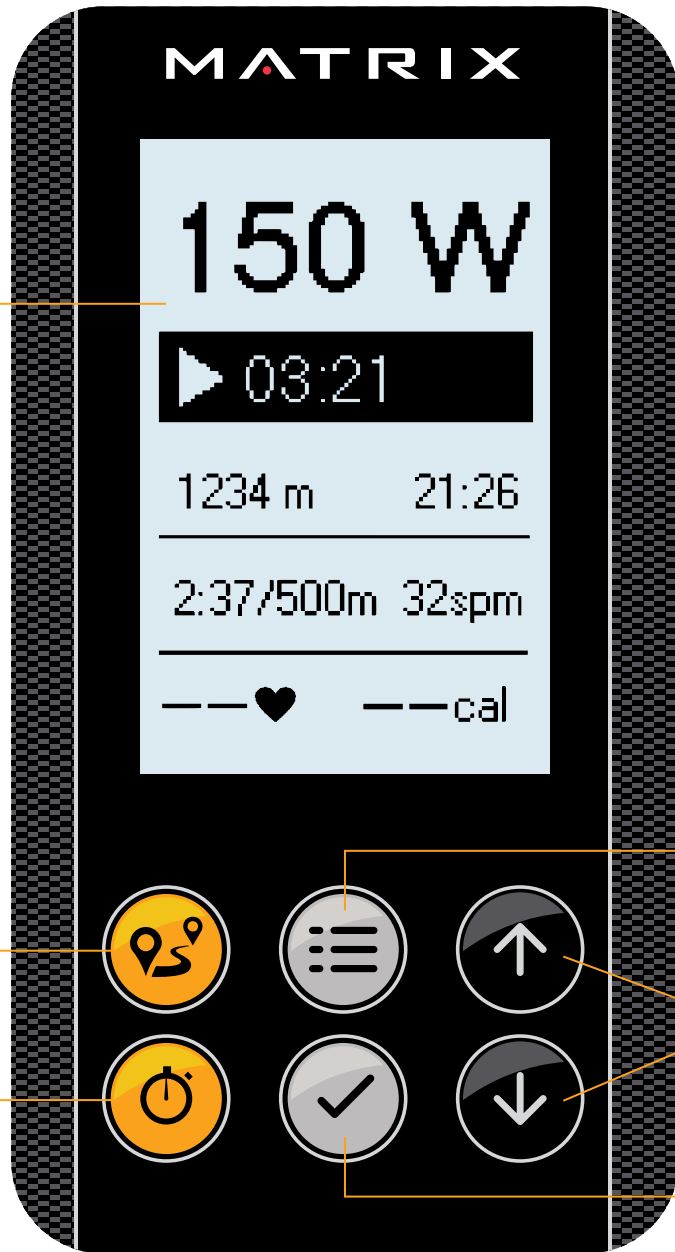



PROPER USAGE

There are four phases to the rowing stroke:

1. **CATCH** – Grasp the handle evenly with both hands. With the seat slid forward and the knees tucked into the chest (directly in line with the heel of the foot), stretch the arms out in front and lean slightly forward from the hips.
2. **DRIVE** – Press firmly against the foot plates until the legs are fully extended, but not locked. Let the arms come with you and bring the torso to 90 degrees.
3. **FINISH** – Pull the arms into the abdomen with legs fully extended, and lean back with the torso slightly beyond 90 degrees.
4. **RECOVERY** – Extend the arms, bend the knees, and lean forward from the hips and slid forward on the seat.

All four phases should be performed smoothly and in a continuous manner.

PROGRAMS

1. **QUICK START** – adjust foot plates to desired position and begin rowing. Console will power up within a few seconds.
2. **MANUAL PROGRAM**
 - Press menu button, select manual and press check to confirm. User arrow keys to select desired time and check to confirm. Begin your workout.
3. **INTERVAL PROGRAM** - allows user to set specific work to rest interval ratios and total number of intervals based on performance goals.
 - Press menu button, arrow down to interval and press check to confirm. Choose time or distance using the arrow keys and check to confirm; select work time and rest time using the arrow keys and press check to confirm; use arrow keys to select number of desired intervals, check to confirm. Begin your interval workout.
4. **CHALLENGE PROGRAM** – allows user to set very specific time and distance targets to ensure they achieve their training objectives. A pace line is set based on these goals and allows the user to chase the goal line.
 - Press menu button and arrow down to challenge and press check to confirm. Set distance using the arrow keys and check to confirm; select time using the arrow keys and check to confirm; start rowing and chase the pace line to meet your target goal.
5. **SUMMARY SCREENS** – after a workout is completed, press the menu button to see average and max values for SPM, Watts, HR, etc.

PROFILE

This menu option allows the user to enter personal data (i.e. gender, age, height, weight) when wearing a HR strap to more accurately calculate calories burned.

OPTION

- **SUPPORT** – shows serial number, firmware version, etc. which are useful if service is needed.
- **DRAG RATIO** – measures how much the flywheel is slowing down to determine how fast or slow the “boat” is. This rate of deceleration is called the drag ratio. For each stroke, the console uses the drag ratio to determine how much work is being done based on the speed of the flywheel. In this way, true effort is calculated regardless of resistance setting. This self-calibration is what allows the user to compare their performance on different indoor rowers.

Different indoor rowers can have different drag ratio ranges. A resistance setting of 3 on one machine may feel like a 4 on another. Differences in belt tension, magnet position, etc. can all affect the drag ratio from machine to machine.

MANAGER MODE

To enter manager mode, press the up and down arrows simultaneously for 3-5 seconds. To exit manager mode, press and hold the menu button for 3 seconds.

- **WORKOUT** – set desired max time, default time, pause time, and default distance
- **USER** – select age, weight, height, gender
- **UNIT** – set console to display metric or standard units
- **SOFTWARE** – version or update options used for troubleshooting and service
- **GENERAL** – shows total distance, time and strokes performed on the rower
- **LANGUAGE** – select language based on region
- **MACHINE** – type, serial number, out of order options used for service
- **LCD** – adjust backlight, brightness and contrast settings

SLEEP MODE

Console will turn off after pause time has expired and go into sleep mode for 30 seconds up to 5 minutes depending on default setting before it shuts off completely.



USING THE HEART RATE FUNCTION

The heart rate function on this product is not a medical device. The heart rate reading is intended only as an exercise aid in determining heart rate trends in general. Please consult your physician.

WIRELESS HEART RATE RECEIVER

When used in conjunction with a **wireless chest transmitter** (sold separately), your heart rate can be transmitted wirelessly to the unit and displayed on the console.

Prior to wearing the wireless chest transmitter on your chest, moisten the two rubber electrodes with water. Center the chest strap just below the breast or pectoral muscles, directly over your sternum, with the logo facing out. NOTE: The chest strap must be tight and properly placed to receive an accurate and consistent readout. If the chest strap is too loose, or positioned improperly, you may receive an erratic or inconsistent heart rate readout.

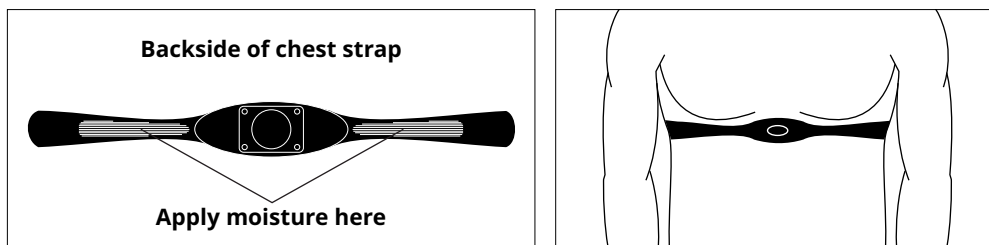

WARNING!

Heart rate monitoring systems may be inaccurate. Over exercising may result in serious injury or death. If you feel faint, stop exercising immediately.

BRAKE SYSTEM AND WATTS TABLE

The Matrix rower utilizes magnetic resistance to set specific levels of resistance. The resistance level setting in addition to the SPM is used to determine the power (watts) output.

MATRIX