



EX-59

ELLIPTICAL OWNER'S MANUAL



Read the ELLIPTICAL GUIDE before using this OWNER'S MANUAL.

ASSEMBLY



WARNING

There are several areas during the assembly process that special attention must be paid. It is very important to follow the assembly instructions correctly and to make sure all parts are firmly tightened. If the assembly instructions are not followed correctly, the elliptical could have frame parts that are not tightened and will seem loose and may cause irritating noises. To prevent damage to the elliptical, the assembly instructions must be reviewed and corrective actions should be taken.

Before proceeding, find your elliptical's serial number located on the front stabilizer tube and enter it in the space provided below.

ENTER YOUR SERIAL NUMBER IN THE BOX BELOW:

SERIAL NUMBER:

| | | | | | | | | | | | | | | | | | | | |
|--|--|--|--|--|--|--|--|--|--|--|--|--|--|--|--|--|--|--|--|
| | | | | | | | | | | | | | | | | | | | |
|--|--|--|--|--|--|--|--|--|--|--|--|--|--|--|--|--|--|--|--|

MODEL NAME: **HORIZON EX-59 ELLIPTICAL**

» Refer to the SERIAL NUMBER and MODEL NAME when calling for service.

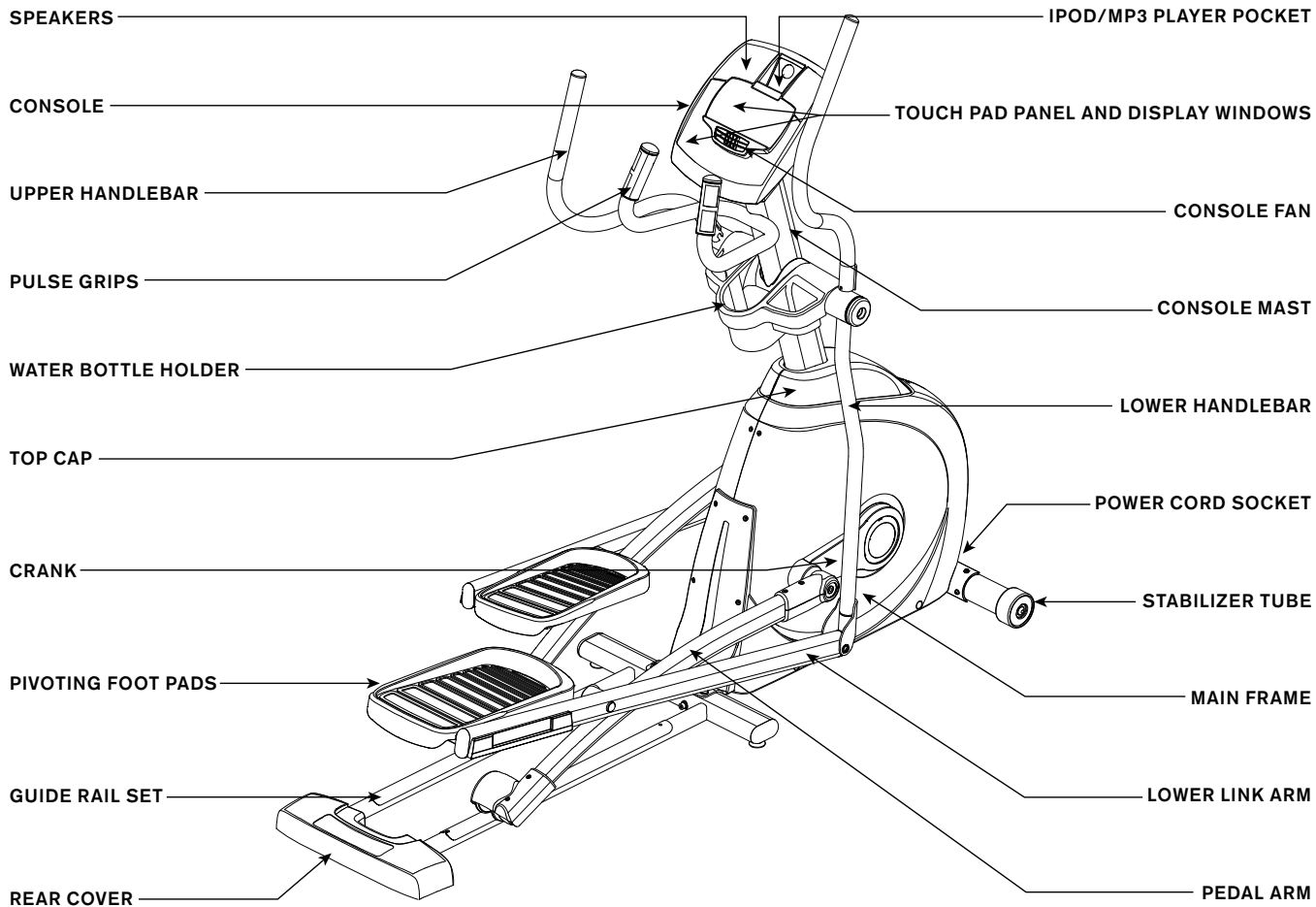

TOOLS INCLUDED:

- Screwdriver
- 8 mm L-Wrench
- 6 mm L-Wrench
- 5 mm L-Wrench
- 13/15 mm Flat Wrench

PARTS INCLUDED:

- 1 Main Frame
- 1 Stabilizer Tube
- 1 Guide Rail Set
- 2 Pedal Arms
- 2 Lower Handlebars
- 2 Upper Handlebars
- 2 Lower Link Arms With Footpads
- 1 Top Cap
- 1 Console Mast
- 1 Console Mast Boot
- 1 Console
- 2 Handlebar Caps
- 1 Water Bottle Holder
- 1 Audio Adapter Cable
- 1 Power Cord
- 7 Hardware Bags

PRE ASSEMBLY

UNPACKING

Unpack the product where you will be using it. Place the elliptical carton on a level flat surface. It is recommended that you place a protective covering on your floor. Never open box when it is on its side.

NOTE: During each assembly step, ensure that ALL nuts and bolts are in place and partially threaded in before completely tightening any ONE bolt.

NOTE: A light application of grease may aid in the installation of hardware. Any grease, such as lithium bike grease is recommended.



NEED HELP?

If you have questions or if there are any missing parts, contact Customer Tech Support. Contact information is located on the back panel of this manual.



ASSEMBLY STEP 1

EX-58 SHOWN

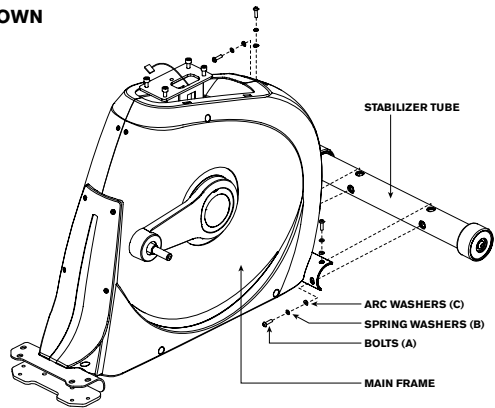

HARDWARE BAG 1 CONTENTS :



BOLT (A)
30 mm
Qty: 4



SPRING WASHER (B)
15 mm
Qty: 4



ARC WASHER (C)
17 mm
Qty: 4

- A Open **HARDWARE BAG 1**.
- B Attach the **STABILIZER TUBE** to the **MAIN FRAME** using 4 **BOLTS (A)**, 4 **SPRING WASHERS (B)** and 4 **ARC WASHERS (C)**.

ASSEMBLY STEP 2

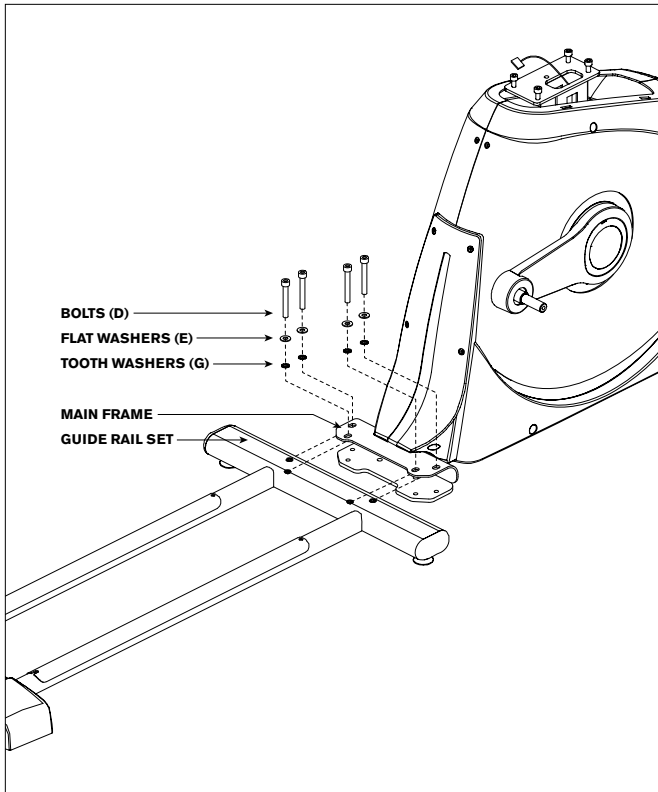

HARDWARE BAG 2 CONTENTS :

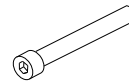

BOLT (D)
55 mm
Qty: 4



FLAT WASHER (E)
17 mm
Qty: 4



TOOTH WASHER (G)
15 mm
Qty: 4

- A Open **HARDWARE BAG 2**.
- B Align **GUIDE RAIL SET** with **MAIN FRAME** as shown.
- C Attach the **GUIDE RAIL SET** to the **MAIN FRAME** using 4 **BOLTS (D)**, 4 **FLAT WASHERS (E)** and 4 **TOOTH WASHERS (G)**.

ASSEMBLY STEP 3

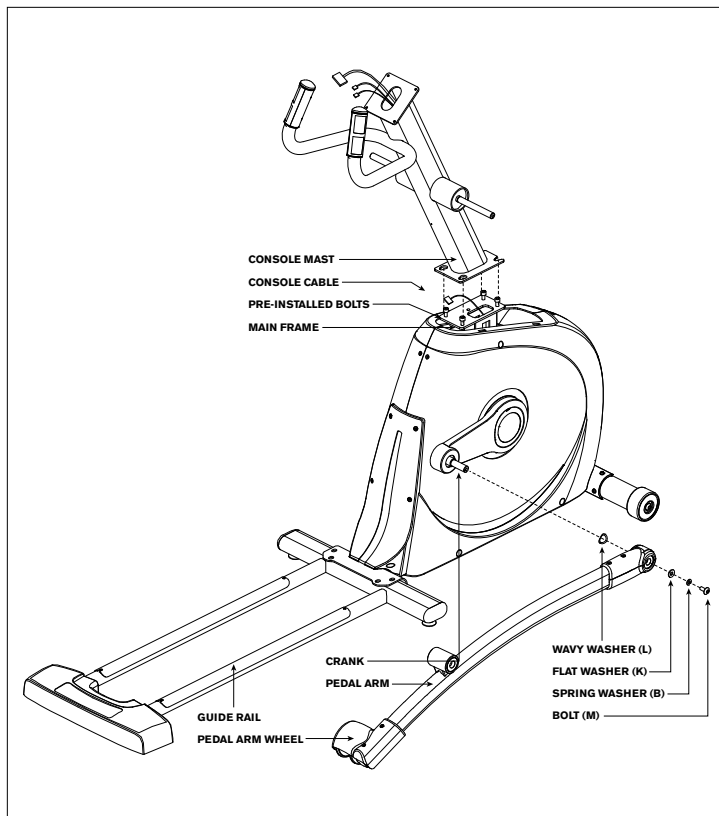

HARDWARE BAG 3 CONTENTS :



- A Open **HARDWARE BAG 3**.
- B Carefully pull the **CONSOLE CABLE** through the **CONSOLE MAST** using the twist tie located inside the **CONSOLE MAST**.
- C Gently slide the **CONSOLE MAST** onto the **MAIN FRAME** and attach **CONSOLE MAST** to **MAIN FRAME** using **PRE-INSTALLED BOLTS**.
- D Slide **WAVY WASHER (L)** over **CRANK** followed by **PEDAL ARM** as shown. Rest **PEDAL ARM WHEEL** on **GUIDE RAIL**.
- E Attach the **PEDAL ARM** to the **CRANK** using 1 **FLAT WASHER (K)**, 1 **SPRING WASHER (B)** and 1 **BOLT (M)**.
- F Repeat steps E–F on the opposite side of the elliptical.

ASSEMBLY STEP 4

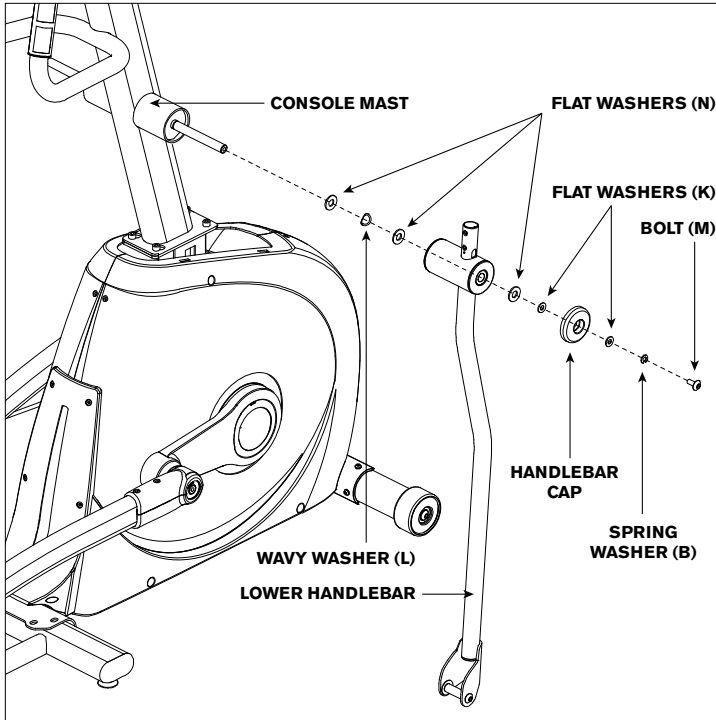

HARDWARE BAG 4 CONTENTS :

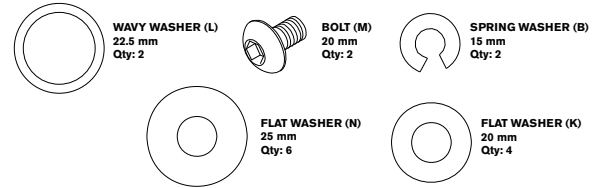

- Open **HARDWARE BAG 4**.
- Slide 1 **FLAT WASHER (N)**, 1 **WAVY WASHER (L)** and another **FLAT WASHER (N)** onto the **CONSOLE MAST**.
- Slide **LOWER HANDLEBAR** onto **CONSOLE MAST** and attach using 1 **FLAT WASHER (N)**, 1 **FLAT WASHER (K)**, 1 **HANDLEBAR CAP**, 1 **SPRING WASHER (B)** and 1 **BOLT (M)**.
- Repeat steps B–C on the opposite side of the elliptical.



ASSEMBLY STEP 5



HARDWARE BAG 5 CONTENTS :

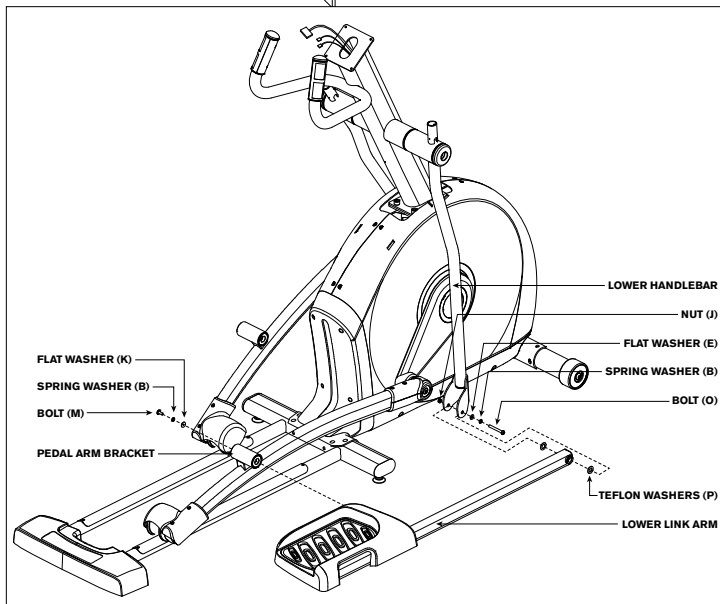
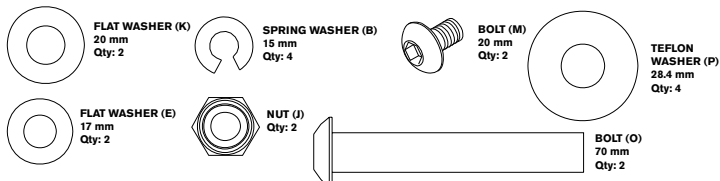

- A Open **HARDWARE BAG 5**.
- B Slide **LOWER LINK ARM** onto **PEDAL ARM BRACKET**.
- C Attach **LOWER LINK ARM** to **PEDAL ARM** using 1 **FLAT WASHER (K)**, 1 **SPRING WASHER (B)** and 1 **BOLT (M)**.
- D Align opposite end of **LOWER LINK ARM** with bracket on bottom of **LOWER HANDLEBAR**.
- E Place **TEFLON WASHERS (P)** on both sides of the **LOWER LINK ARM**. While holding **TEFLON WASHERS (P)** slide **LOWER LINK ARM** into bottom end of **LOWER HANDLEBAR**.
- F Secure the joint with 1 **FLAT WASHER (E)**, 1 **SPRING WASHER (B)**, 1 **BOLT (O)** and secure with 1 **NUT (J)**.
- G Repeat steps B–F on the opposite side of the elliptical.

ASSEMBLY STEP 6



HARDWARE BAG 7 CONTENTS :

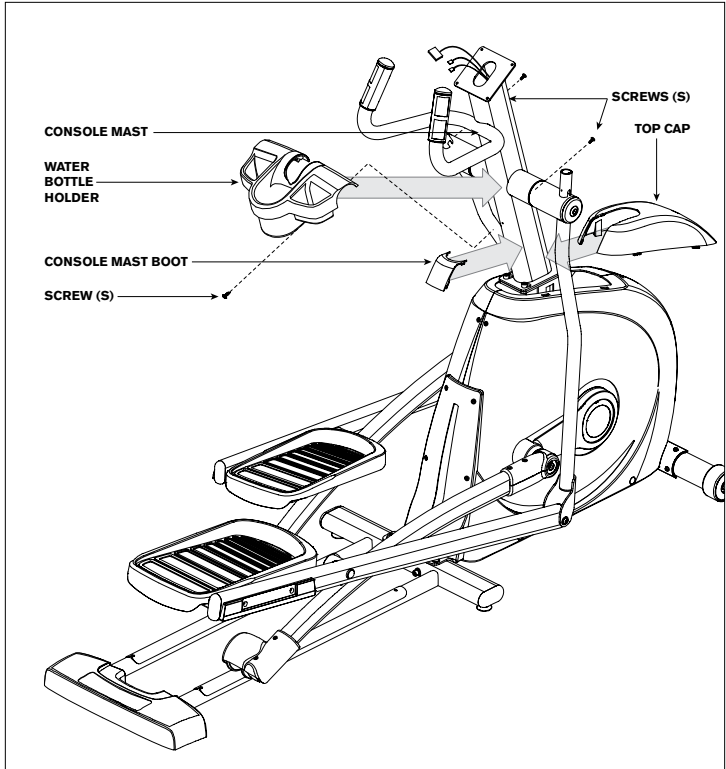

- A Open **HARDWARE BAG 7**.
- B Slide **TOP CAP** over **CONSOLE MAST** and snap into place.
- C Insert **CONSOLE MAST BOOT** over **TOP CAP** and snap into place.
- D Slide **WATER BOTTLE HOLDER** over **CONSOLE MAST** and attach using 3 **SCREWS (S)**.

ASSEMBLY STEP 8

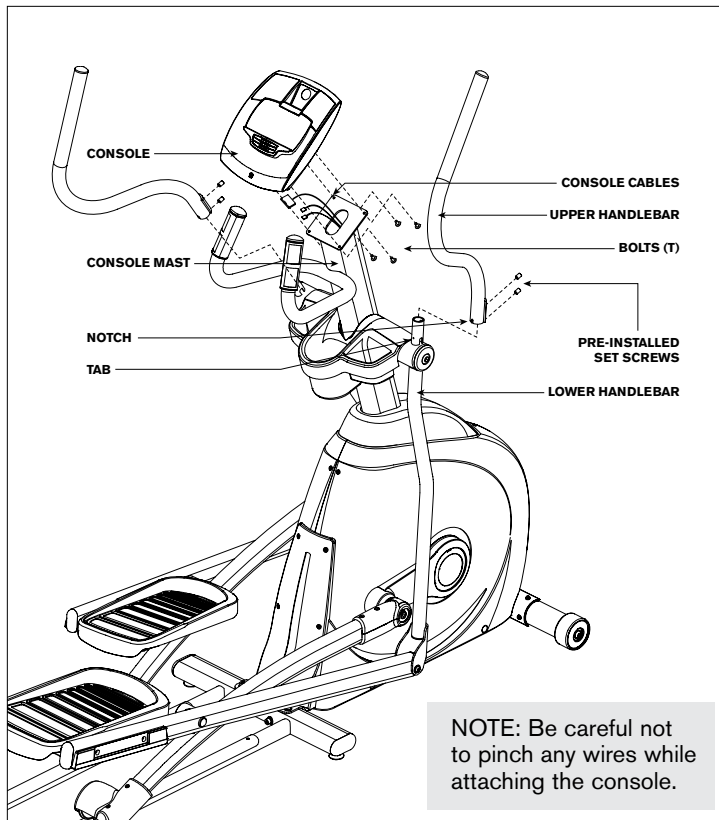

HARDWARE BAG 8 CONTENTS :



- A Open **HARDWARE BAG 8**.
- B Attach the **CONSOLE CABLES** to the **CONSOLE**.
- C Carefully tuck the **CONSOLE CABLES** into the **CONSOLE MAST** before attaching the **CONSOLE**. Attach **CONSOLE** to **CONSOLE MAST** using 4 **BOLTS (T)**.
- D Slide **UPPER HANDLEBARS** onto **LOWER HANDLEBARS** and align **NOTCH** with **TAB** making sure handlebars are joined together completely. Secure **UPPER HANDLEBARS** to **LOWER HANDLEBARS** using **PRE-ATTACHED SET SCREWS**.
- E Repeat step D on other side.

YOU ARE FINISHED!

ELLIPTICAL OPERATION



This section explains how to use your elliptical's console and programming.
The BASIC OPERATION section in the ELLIPTICAL GUIDE has instructions for the following:

- **LOCATION OF THE ELLIPTICAL**
- **POWER/GROUNDING INSTRUCTIONS**
- **FOOT POSITIONING**
- **MOVING THE ELLIPTICAL**
- **LEVELING THE ELLIPTICAL**
- **POWER/MANUAL INCLINE OPERATION**
- **USING THE HEART RATE FUNCTION**

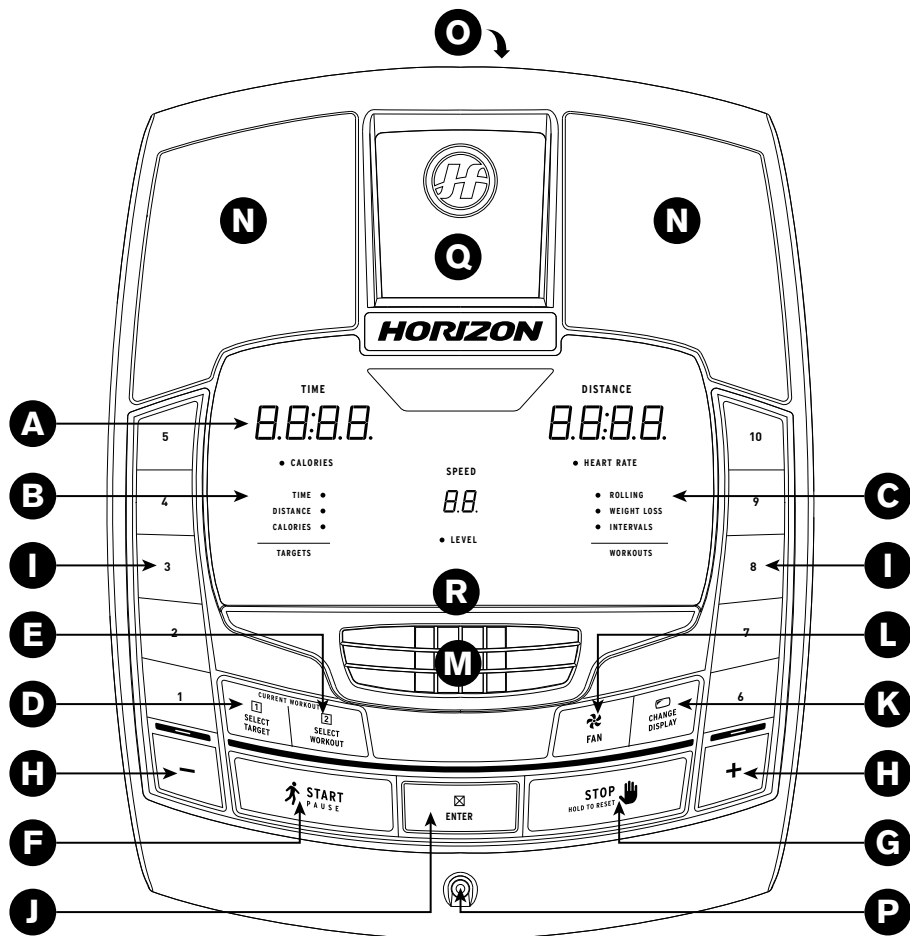

CONSOLE OPERATION

Note: There is a thin protective sheet of clear plastic on the overlay of the console that should be removed before use.

- A) **LED DISPLAY WINDOWS:** time, distance, calories, heart rate, speed and resistance level.
- B) **TARGET LED INDICATORS:** indicate what target (if any) is set for the current program.
- C) **WORKOUT LED INDICATORS:** indicate what workout (if any) is set for the current program.
- D) **SELECT TARGET:** press to select your desired target.
- E) **SELECT WORKOUT:** press to select your desired workout.
- F) **START:** press to begin exercising, start your workout, or resume exercising after pause.
- G) **STOP:** press to pause/end your workout. Hold for 3 seconds to reset the console.
- H) **+ / - KEYS:** used to adjust resistance level.
- I) **QUICK KEYS:** used to reach desired resistance level more quickly.
- J) **ENTER:** used to confirm a selection.
- K) **CHANGE DISPLAY:** press to change display feedback during workout.
- L) **FAN KEY:** press to turn fan on and off.
- M) **FAN:** personal workout fan.
- N) **SPEAKERS:** music plays through speakers when your CD / MP3 player is connected to the console.
- O) **AUDIO IN JACK:** plug your CD / MP3 player into the console using the included audio adaptor cable.
- P) **AUDIO OUT / HEADPHONE JACK:** plug your headphones into this jack to listen to your music through the headphones.
Note: when headphones are plugged into the headphone jack the sound will no longer come out through the speakers.
- Q) **MP3 PLAYER POCKET:** used to store your MP3 player.
- R) **READING RACK:** holds reading material.



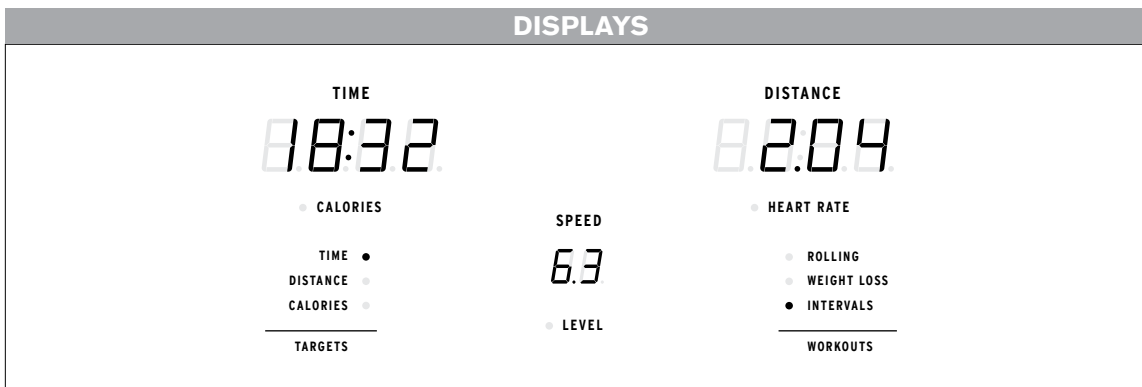

DISPLAY WINDOWS

- **TIME:** Shown as minutes : seconds. View the time remaining or the time elapsed in your workout.
- **DISTANCE:** Shown as miles. Indicates distance traveled or distance remaining during your workout.
- **SPEED:** Shown as MPH. Indicates how fast the foot pedals are moving.
- **CALORIES:** Total calories burned or calories remaining left to burn during your workout.
- **HEART RATE:** Shown as BPM (beats per minute). Used to monitor your heart rate (displayed when contact is made with both pulse grips).
- **LEVEL:** Shows the current level of resistance.
- **TARGETS:** LED lights up next to currently selected target. If no LED is lit, no target is activated.
- **WORKOUTS:** LED lights up next to currently selected workout. If no LED is lit, no workout is activated.

GETTING STARTED

- 1) Check to make sure no objects are nearby that will hinder the movement of the elliptical.
- 2) Plug in the power cord and turn the elliptical ON. (Switch is located at the bottom-front of the elliptical.)
NOTE: Some ellipticals may not have a power switch and will turn on when power is supplied.

A) QUICK START UP

Simply press the START key to begin working out.

The time will count up from 0:00, the resistance level will default to level 1. OR...

B) SELECT A TARGET AND WORKOUT

- 1) Select a TARGET using the SELECT TARGET key.
- 2) Adjust the TARGET settings using the ARROW keys.
- 3) Press ENTER to advance.
- 4) Select a WORKOUT using the SELECT WORKOUT key.
- 5) Press START to begin workout.

NOTE: If no TARGET nor WORKOUT is selected, the program will function as a MANUAL program. All changes in resistance level or incline will need to be from the user in this setting.



PROGRAM INFORMATION



TARGET 1 – TIME: Allows user to set a target based on how long they would like to workout. Time targets can range from 15:00 – 99:00(EX-68, EX-78, e1100GS) or 5:00 – 99:00(EX-58, CE5.1). TIME will count down. DISTANCE and CALORIES will count up from zero.



TARGET 2 – DISTANCE: Allows user to set a target based on distance they would like to complete. Distance target can range from 0.25 – 26.25 miles. DISTANCE will count down. TIME and CALORIES will count up from zero.



TARGET 3 – CALORIES: Allows user to set a target based on the number of calories they would like to burn. Calories target can range from 20 – 980 calories. CALORIES will count down. TIME and DISTANCE will count up from zero.



NO TARGET: Allows user to select a workout profile that has no specified time, distance, or calorie target. TIME, DISTANCE, and CALORIES will all count up from zero.



WORKOUT 1 – ROLLING: Resistance program. Mimics the feeling of moving up and down hills by gradually increasing and decreasing the resistance.



WORKOUT 2 – WEIGHT LOSS: Promotes weight loss by increasing and decreasing the resistance, while keeping you in your fat burning zone.



WORKOUT 3 – INTERVALS: Improves your strength, speed and endurance by increasing and decreasing the resistance throughout your workout to involve your heart and other muscles.

TO RESET THE CONSOLE

Hold STOP key for 3 seconds.



FINISHING YOUR WORKOUT

When your workout is complete, the monitor display will flash "FINISHED" and beep. Your workout information will stay displayed on the console for 30-45 seconds and then reset.

CLEAR CURRENT SELECTION

To clear the current program selection or screen, hold the STOP button for 3-5 seconds.

USING YOUR CD / MP3 PLAYER

-  1) Connect the included AUDIO ADAPTOR CABLE to the AUDIO IN JACK on the top right of the console and the headphone jack on your CD / MP3 player.
- 2) Use your CD / MP3 player buttons to adjust song settings.
- 3) Remove the AUDIO ADAPTOR CABLE when not in use.
-  4) If you don't want to use the SPEAKERS, you can plug your headphones into the AUDIO OUT JACK at the bottom of the console.



LIMITED HOME-USE WARRANTY





WEIGHT CAPACITY = 275 lbs (125 kilograms)

FRAME • LIFETIME

Horizon Fitness warrants the frame against defects in workmanship and materials for the lifetime of the original owner, so long as the device remains in the possession of the original owner. (The frame is defined as the welded metal base of the unit and does not include any parts that can be removed.)

BRAKE • 20 YEARS

Horizon Fitness warrants the brake against defects in workmanship and materials for the period specified above from the date of original purchase, so long as the device remains in the possession of the original owner.

ELECTRONICS & PARTS • 1 YEAR

Horizon Fitness warrants the electronic components, finish and all original parts for the period specified above from the date of original purchase, so long as the device remains in the possession of the original owner.

LABOR • 1 YEAR

Horizon Fitness shall cover the labor cost for the repair of the device for a period of one year from the date of the original purchase, so long as the device remains in the possession of the original owner.

EXCLUSIONS AND LIMITATIONS

Who IS covered:

- The original owner and is not transferable.

What IS covered:

- Repair or replacement of a defective motor, electronic component, or defective part and is the sole remedy of the warranty.

What IS NOT covered:

- Normal wear and tear, improper assembly or maintenance, or installation of parts or accessories not originally intended or compatible with the equipment as sold.
- Damage or failure due to accident, abuse, corrosion, discoloration of paint or plastic, neglect, theft, vandalism, fire, flood, wind, lightning, freezing, or other natural disasters of any kind, power reduction, fluctuation or failure from whatever cause, unusual atmospheric conditions, collision, introduction of foreign objects into the covered unit, or modifications that are unauthorized or not recommended by Horizon Fitness.

SERVICE/RETURNS

- Incidental or consequential damages. Horizon Fitness is not responsible or liable for indirect, special or consequential damages, economic loss, loss of property, or profits, loss of enjoyment or use, or other consequential damages of whatsoever nature in connection with the purchase, use, repair or maintenance of the equipment.
- Equipment used for commercial purposes or any use other than a single family or Household, unless endorsed by Horizon Fitness for coverage.
- Equipment owned or operated outside the US and Canada.
- Delivery, assembly, installation, setup for original or replacement units or labor or other costs associated with removal or replacement of the covered unit.
- Any attempt to repair this equipment creates a risk of injury. Horizon Fitness is not responsible or liable for any damage, loss or liability arising from any personal injury incurred during the course of, or as a result of any repair or attempted repair of your fitness equipment by other than an authorized service technician. All repairs attempted by you on your fitness equipment are undertaken AT YOUR OWN RISK and Horizon Fitness shall have no liability for any injury to the person or property arising from such repairs.
- In-home service is available within 150 miles of the nearest authorized repair center (Mileage beyond 150 miles from an authorized service center is the responsibility of the consumer).
- All returns must be pre-authorized by Horizon Fitness.
- Horizon Fitness' obligation under this warranty is limited to replacing or repairing, at Horizon Fitness' option, the same or comparable model at one of its authorized service centers.
- A Horizon Fitness authorized service center must receive all equipment for which a warranty claim is made. This equipment must be received with all freight and other transportation charges prepaid, accompanied by sufficient proof of purchase.
- Replacement units, parts and electronic components reconditioned to as-new condition by Horizon Fitness or its vendors may sometimes be supplied as warranty replacement and constitute fulfillment of warranty terms.
- This warranty gives you specific legal rights, and your rights may vary from state to state.



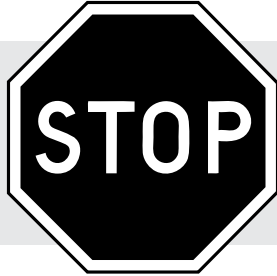

CUSTOMER TECH SUPPORT

DO NOT RETURN TO THE RETAILER

if you have any problems during assembly or if parts are missing.

NOTE: Please read the TROUBLESHOOTING section in the ELLIPTICAL GUIDE before contacting Customer Tech Support.



1-800-244-4192
comments@horizonfitness.com
www.horizonfitness.com

Horizon Fitness
1600 Landmark Drive,
Cottage Grove WI, 53527