

***HORIZON CLUB***



***FOR MODELS :***

---

***T700***

---

***T800***

---



***HORIZON***  
FITNESS

***TREADMILL USER'S GUIDE***

# INTRODUCTION

**CONGRATULATIONS** and **THANK YOU** for your purchase of this Horizon Club Treadmill!

Whether your goal is to win races or simply enjoy a fuller, healthier lifestyle, a Horizon Club treadmill can help you attain it – adding club-quality performance to your at-home workouts, with the ergonomics and innovative features you need to get stronger and healthier, faster. Because we're committed to designing fitness equipment from the inside out, we use only the highest quality components. It's a commitment we back with one of the strongest frame-to-motor warranty packages in the industry.

You want exercise equipment that offers the most comfort, the best reliability and the highest quality in its class.

**Horizon Club Treadmills deliver.**

## TABLE OF CONTENTS

|  |                   |
|--|-------------------|
| <i>Important Precautions</i>             | <i>4</i>          |
| <i>Assembly</i>                          | <i>6</i>          |
| <i>Before You Begin</i>                  | <i>13</i>         |
| <i>Treadmill Operation</i>               | <i>16</i>         |
| <i>Conditioning Guidelines</i>           | <i>24</i>         |
| <i>Troubleshooting &amp; Maintenance</i> | <i>31</i>         |
| <i>Limited Warranty</i>                  | <i>34</i>         |
| <b>CONTACT INFORMATION</b>               | <i>Back Panel</i> |

# IMPORTANT PRECAUTIONS

## SAVE THESE INSTRUCTIONS

Read all instructions before using this treadmill. When using an electrical product, basic precautions should always be followed, including the following: Read all instructions before using this treadmill. It is the responsibility of the owner to ensure that all users of this treadmill are adequately informed of all warnings and precautions. If you have any questions after reading this manual, contact Customer Tech Support at the number listed on the back panel of this manual.



Connect this exercise product to a properly grounded outlet only. See grounding instructions.

## GROUNDING INSTRUCTIONS

This product must be grounded. If a treadmill should malfunction or breakdown, grounding provides a path of least resistance for electrical current to reduce the risk of electrical shock. This product is equipped with a cord having an equipment-grounding conductor and a grounding plug. The plug must be plugged into an appropriate outlet that is properly installed and grounded in accordance with local codes and ordinances.



Improper connection of the equipment-grounding conductor can result in a risk of electric shock. Check with a qualified electrician or serviceman if you are in doubt as to whether the product is properly grounded. Do not modify the plug provided with the product. If it will not fit the outlet, have a proper outlet installed by a qualified electrician.

This product is for use on a nominal 110-volt circuit and has a grounding plug that looks like the illustration below. This product must be used on a dedicated circuit. To determine if you are on a dedicated circuit, shut off the power to that circuit and observe if any other devices lose power. If so, move devices to a different circuit. **Note:** There are usually multiple outlets on one circuit. It is recommended that the treadmill be used with a 20 amp circuit for optimal performance.

### 3-Pole Grounded Outlet

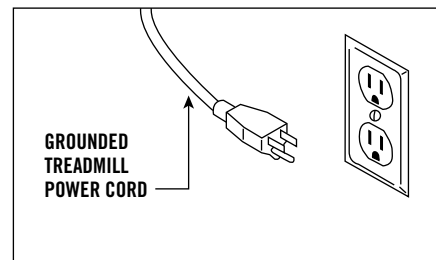



*To reduce the risk of burns, fire, electrical shock or injury to persons:*

- *Never use the treadmill before securing the safety tether clip to your clothing.*
- *If you experience any kind of pain, including but not limited to chest pains, nausea, dizziness, or shortness of breath, stop exercising immediately and consult your physician before continuing.*
- *Do not wear clothes that might catch on any part of the treadmill.*
- *Always wear athletic shoes while using this equipment.*
- *Do not jump on the treadmill.*
- *Keep power cord away from heated surfaces.*
- *Do not insert or drop any object into any opening.*
- *Unplug treadmill before moving or cleaning it. To clean, wipe surfaces down with soap and slightly damp cloth only; never use solvents. (See MAINTENANCE)*
- *At no time should more than one person be on treadmill while in operation.*
- *This treadmill should not be used by persons weighing more than 300 pounds. Failure to comply will void the warranty.*
- *This treadmill is intended for in-home use only. Do not use this treadmill in any commercial, rental, school or institutional setting. Failure to comply will void the warranty.*
- *Do not use treadmill in any location that is not temperature controlled, such as but not limited to garages, porches, pool rooms, bathrooms, car ports or outdoors. Failure to comply may void the warranty.*
- *Use the treadmill only as described in this manual.*



*At NO time should pets or children under the age of 12 be closer to the treadmill than 10 feet.  
At NO time should children under the age of 12 use the treadmill.  
Children over the age of 12 should not use the treadmill without adult supervision.*

## **OTHER SAFETY TIPS FOR YOUR TREADMILL**



### **OPERATION**

*To reduce the risk of damaging important components on your treadmill, it is strongly recommended that your treadmill is plugged into a dedicated 20 amp circuit, without the use of an additional extension cord and/or power strip. Failure to comply may void the warranty.*

**IMPORTANT:** *The treadmill is not compatible with GFCI-equipped outlets.*

*It is essential that your treadmill is used only indoors, in a climate controlled room. If your treadmill has been exposed to colder temperatures or high moisture climates, it is strongly recommended that the treadmill is warmed up to room temperature before first time use. Failure to do so may cause premature electronic failure.*

# ASSEMBLY

## **IMPORTANT: READ THESE SAFETY INSTRUCTIONS BEFORE USE!**



During the assembly process of the treadmill there are several areas that special attention must be paid. It is very important to follow the assembly instructions correctly and to make sure all parts are firmly tightened. If the assembly instructions are not followed correctly, the treadmill could have frame parts that are not tightened and will seem loose and may cause irritating noises. There should be no side-to-side play in the console masts or any forward and back play in the console assembly or handlebars. If there is any play in these areas, the treadmill has not been properly assembled. To prevent damage to the treadmill, the assembly instructions must be reviewed and corrective actions should be taken.

## **UNPACKING**

Place the treadmill carton on a level flat surface. It is recommended that you place a protective covering on your floor. Take CAUTION when handling and transporting this unit. Never open box when it is on its side. Once the banding straps have been removed, do not lift or transport this unit unless it is fully assembled and in the upright folded position, with the lock latch secure. Unpack the unit where it will be used. The enclosed treadmill is equipped with high-pressure shocks and may spring open if mishandled. Never grab hold of any portion of the incline frame and attempt to lift or move the treadmill. FAILURE TO FOLLOW THESE INSTRUCTIONS COULD RESULT IN INJURY!

Before proceeding, find your treadmill's serial number and model name located to the left of the on / off power switch and power cord and enter it in the space provided below.

### **ENTER YOUR SERIAL NUMBER AND MODEL NAME IN THE BOXES BELOW:**

SERIAL NUMBER:

MODEL NAME:

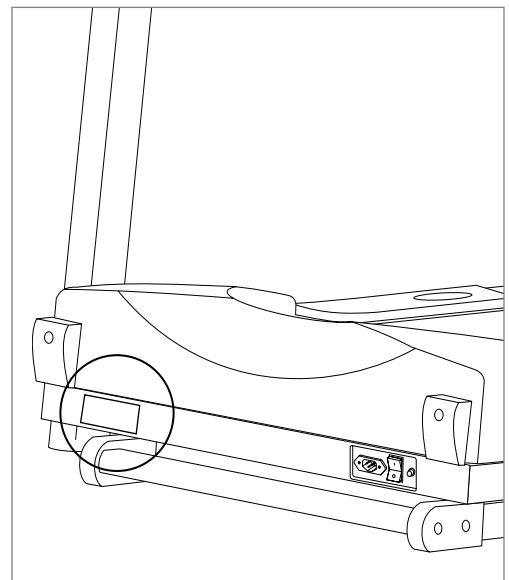

\* Refer to the SERIAL NUMBER and MODEL NAME when calling for service.

\* Also enter this serial number on your Warranty Card.

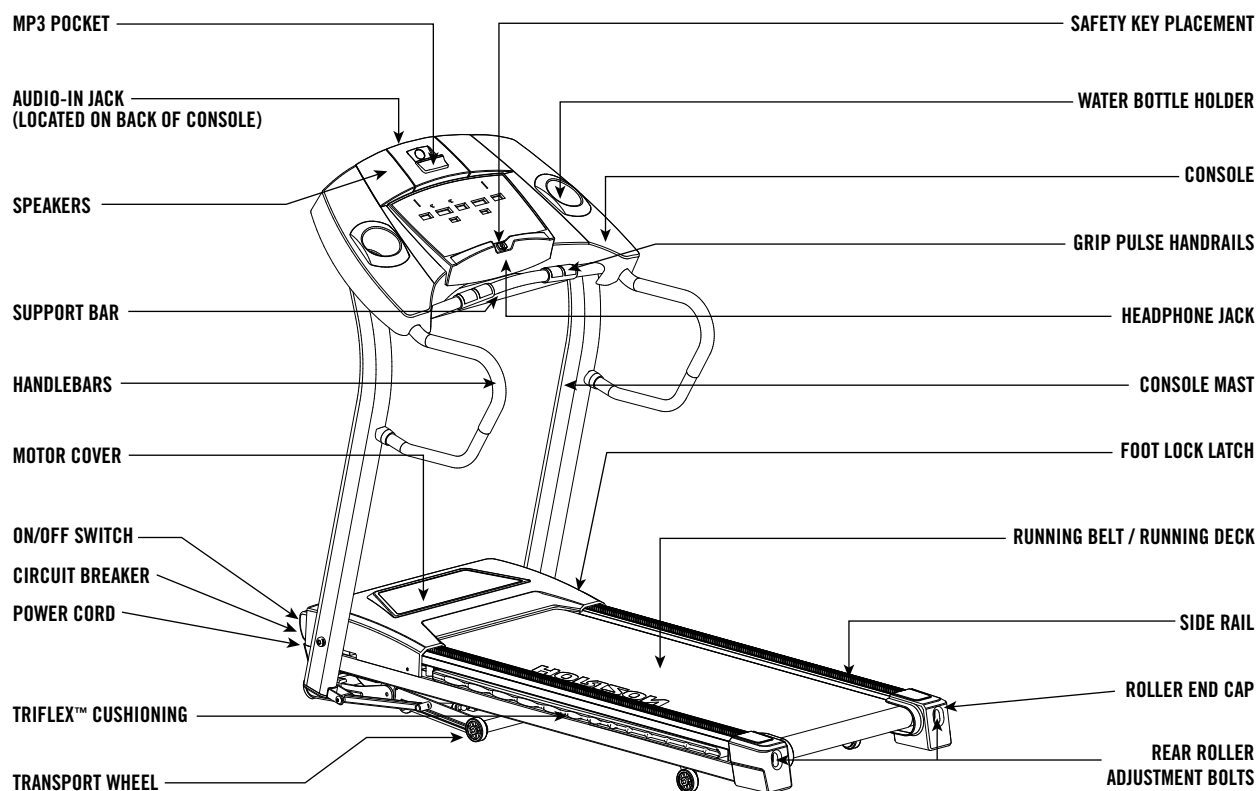

## TOOLS INCLUDED

- |  |   |
|--|---|
| <input type="checkbox"/> Screwdriver   | <input type="checkbox"/> 17mm Flat Wrench |
| <input type="checkbox"/> 5 mm T-wrench | <input type="checkbox"/> 4 mm L-wrench    |
| <input type="checkbox"/> 6 mm T-wrench | <input type="checkbox"/> 10 mm L-wrench   |

## PARTS INCLUDED

- |   |   |
|---|---|
| <input type="checkbox"/> 1 Console Assembly<br>(located under treadmill deck) | <input type="checkbox"/> 5 Hardware Bags                |
| <input type="checkbox"/> 2 Console Masts                                      | <input type="checkbox"/> 1 Safety Key                   |
| <input type="checkbox"/> 2 Handlebars   | <input type="checkbox"/> 1 Power Cord                   |
| <input type="checkbox"/> 1 Support Bar  | <input type="checkbox"/> 1 Bottle of Silicone Lubricant |
|   | <input type="checkbox"/> 1 Audio Adaptor Cable          |

If you have questions or if there are any missing parts, contact Customer Tech Support.  
Contact information is located on the back panel of this manual.

For a complete exploded diagram, visit us at [www.horizonfitness.com](http://www.horizonfitness.com)

## PRE-ASSEMBLY



**DO NOT ATTEMPT TO LIFT THE TREADMILL!\*** Do not move or lift treadmill from packaging until specified to do so in the assembly instructions. Failure to do so may result in injury! Remove plastic wrap from console masts.

**NOTE:** During each assembly step, ensure that ALL nuts and bolts are in place and partially threaded in before completely tightening any ONE bolt. NOTE: A light application of grease may aid in the installation of hardware. Any grease, such as lithium bike grease is recommended.

## ASSEMBLY STEP 1

### HARDWARE BAG 1 CONTENTS :

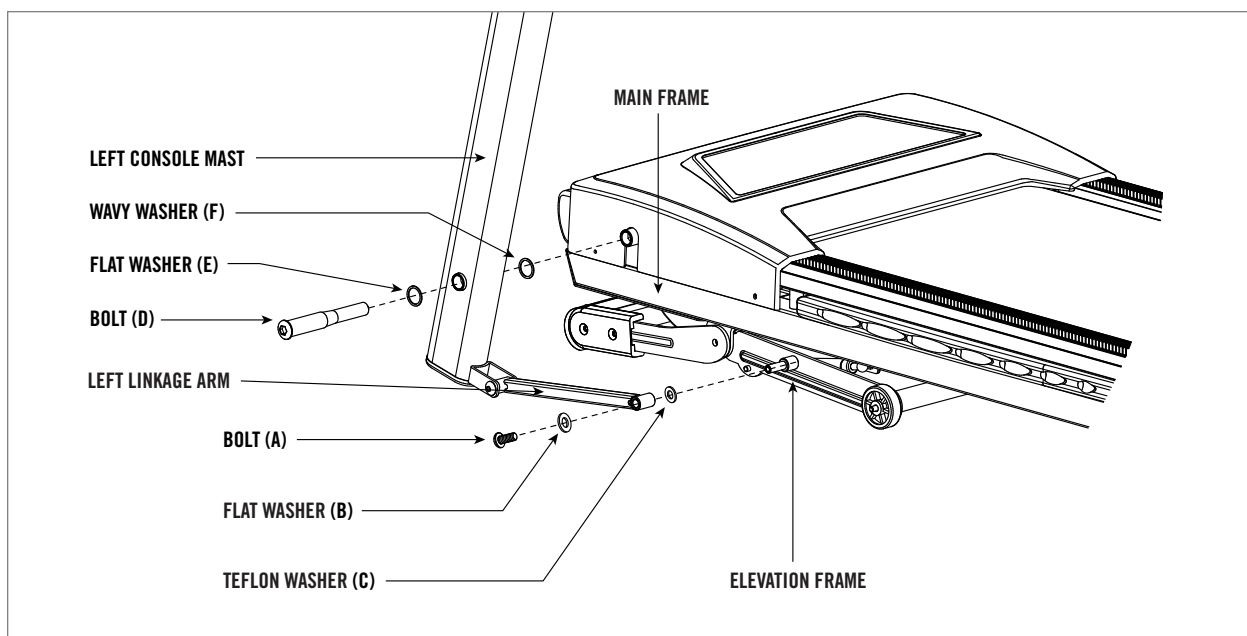
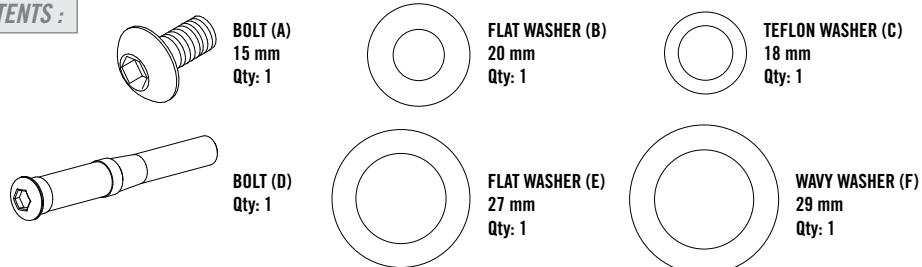

- A** Open **HARDWARE BAG 1**.
- B** Cut banding straps. Do not move or lift treadmill from packaging.
- C** Move **LEFT LINKAGE ARM** into position. Insert 1 **BOLT (A)** and 1 **FLAT WASHER (B)** into **LEFT LINKAGE ARM** followed by 1 **TEFLON WASHER (C)** and attach to **ELEVATION FRAME**.
- D** Lift **LEFT CONSOLE MAST** into upright position. Be sure to hold the console mast firmly, as it will not stay in the upright position on its own.
- E** Insert 1 **BOLT (D)** and 1 **FLAT WASHER (E)** through **LEFT CONSOLE MAST** followed by 1 **WAVY WASHER (F)** and attach to **MAIN FRAME**.

## ASSEMBLY STEP 2

### HARDWARE BAG 2 CONTENTS :

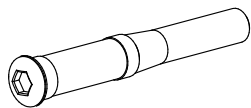

**BOLT (D)**  
Qty: 1

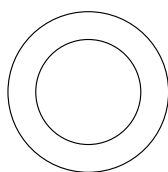

**FLAT WASHER (E)**  
27 mm  
Qty: 1

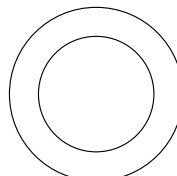

**WAVY WASHER (F)**  
29 mm  
Qty: 1

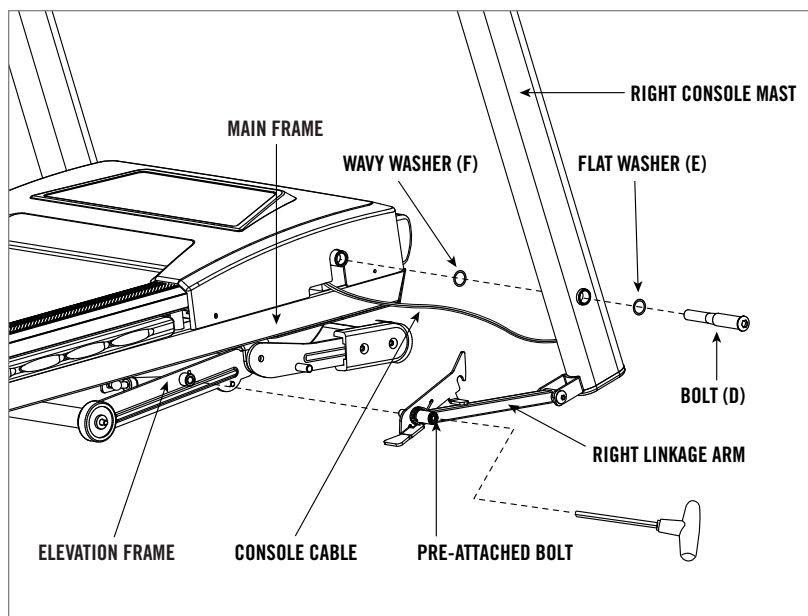
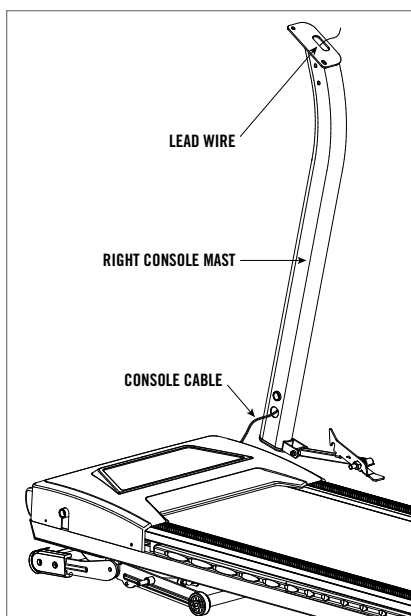

**A** Pull **LEAD WIRE** through **RIGHT CONSOLE MAST**. After pulling the **LEAD WIRE** through the mast, the top of the **CONSOLE CABLE** should be located at the top of the mast. Detach and discard **LEAD WIRE**.

**B** Open **HARDWARE BAG 2**.

**C** Move **RIGHT LINKAGE ARM** into position and attach to **ELEVATION FRAME**.

**NOTE:** While holding **RIGHT CONSOLE MAST** in the upright position, tighten **PRE-ATTACHED BOLT** using T-wrench to attach **RIGHT LINKAGE ARM**.

**D** Insert 1 **BOLT (D)** and 1 **FLAT WASHER (E)** through **RIGHT CONSOLE MAST** followed by 1 **WAVY WASHER (F)** and attach to **MAIN FRAME**.

**E** Lift the **RUNNING DECK** until lock latch on side of treadmill is fully engaged.

**F** Remove **CONSOLE** from box and place out of the way.

**G** Lower the treadmill **RUNNING DECK** from the folded position by stepping on **LOCK LATCH** on lower right side.

\* **NOTE:** If you have attempted to move the treadmill from the box and the machine has sprung open and cannot be assembled, refer to the troubleshooting section in order to restore the treadmill to its proper position.

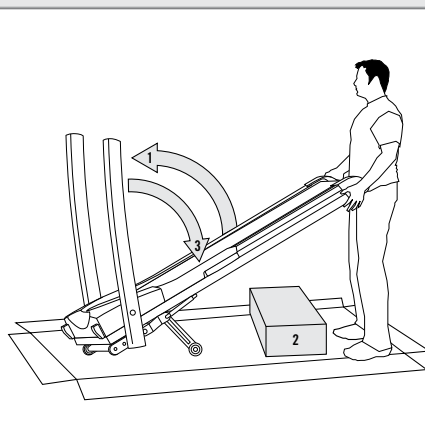



## ASSEMBLY STEP 3

## HARDWARE BAG 3 CONTENTS :

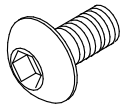

**BOLT (G)**  
20 mm  
Qty: 4

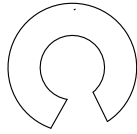

**SPRING WASHER (H)**  
15 mm  
Qty: 4

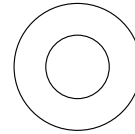

**FLAT WASHER (B)**  
20 mm  
Qty: 4

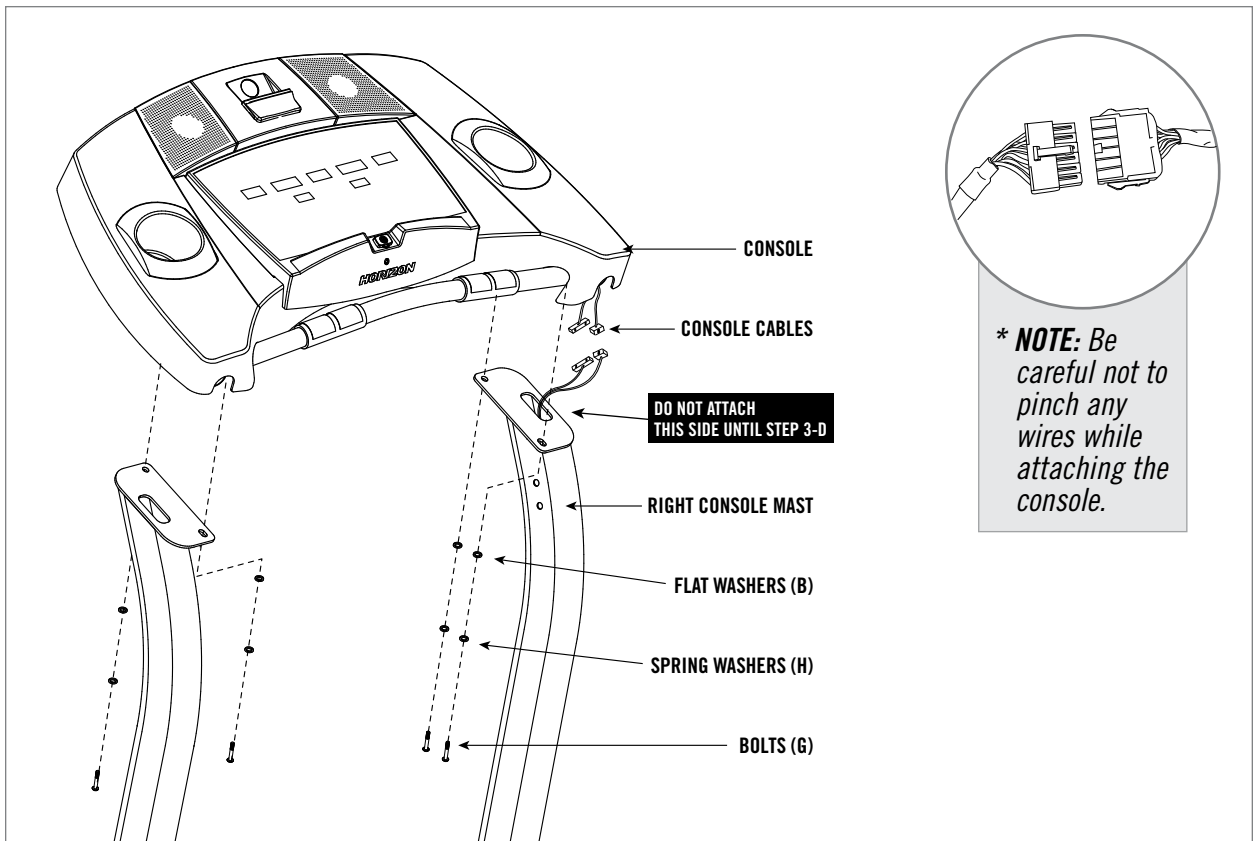

**\* NOTE:** Be careful not to pinch any wires while attaching the console.

- A** Open **HARDWARE BAG 3**.
- B** With running deck in lowered position, place **CONSOLE** on upright masts. Align the brackets that are underneath the console with the top holes of the upright masts.
- C** To assemble the **LEFT CONSOLE MAST** to the **CONSOLE**, insert 1 **BOLT (G)**, 1 **SPRING WASHER (H)** and 1 **FLAT WASHER (B)** into the 2 holes in the **LEFT CONSOLE MAST** and lightly tighten.
- D** Gently lift **RIGHT** side of the **CONSOLE** to connect the **CONSOLE CABLE**. Carefully tuck wires in mast to avoid damage. **NOTE:** Do not pinch console cable or grip pulse wires.
- E** Repeat **STEP C** above to attach the **RIGHT CONSOLE MAST** to the **CONSOLE**.
- F** Tighten console bolts completely.

## ASSEMBLY STEP 4

### HARDWARE BAG 4 CONTENTS :



**BOLT (I)**  
15 mm  
Qty: 4

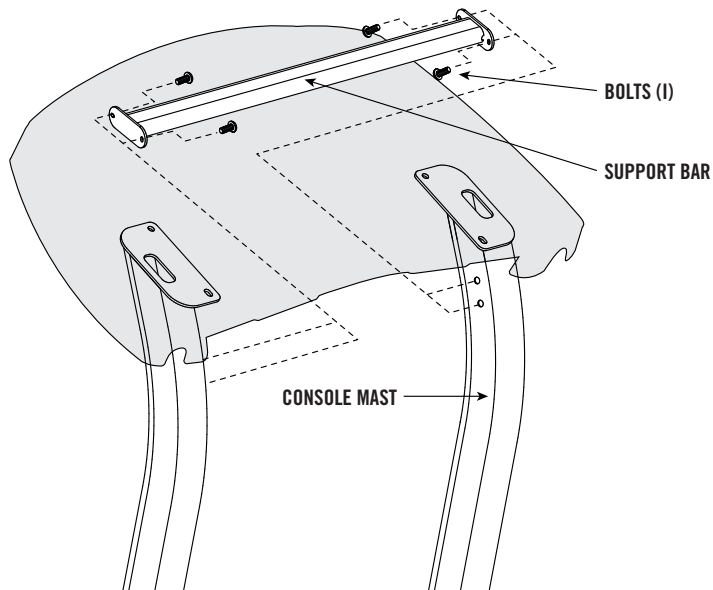

- A** Open **HARDWARE BAG 4**.
- B** Align **SUPPORT BAR** with holes in **CONSOLE MASTS**.
- C** Insert **BOLTS (I)** into all 4 holes of the **SUPPORT BAR**.  
*NOTE: Look into holes in the right mast before inserting bolts to avoid pinching cables.*
- D** Tighten support bar bolts completely.

## ASSEMBLY STEP 5

### HARDWARE BAG 5 CONTENTS :

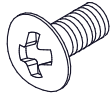

**BOLT (J)**  
10 mm  
Qty: 6

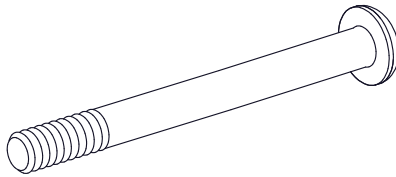

**BOLT (K)**  
115 mm  
Qty: 2



**ARC WASHER (L)**  
Qty: 2

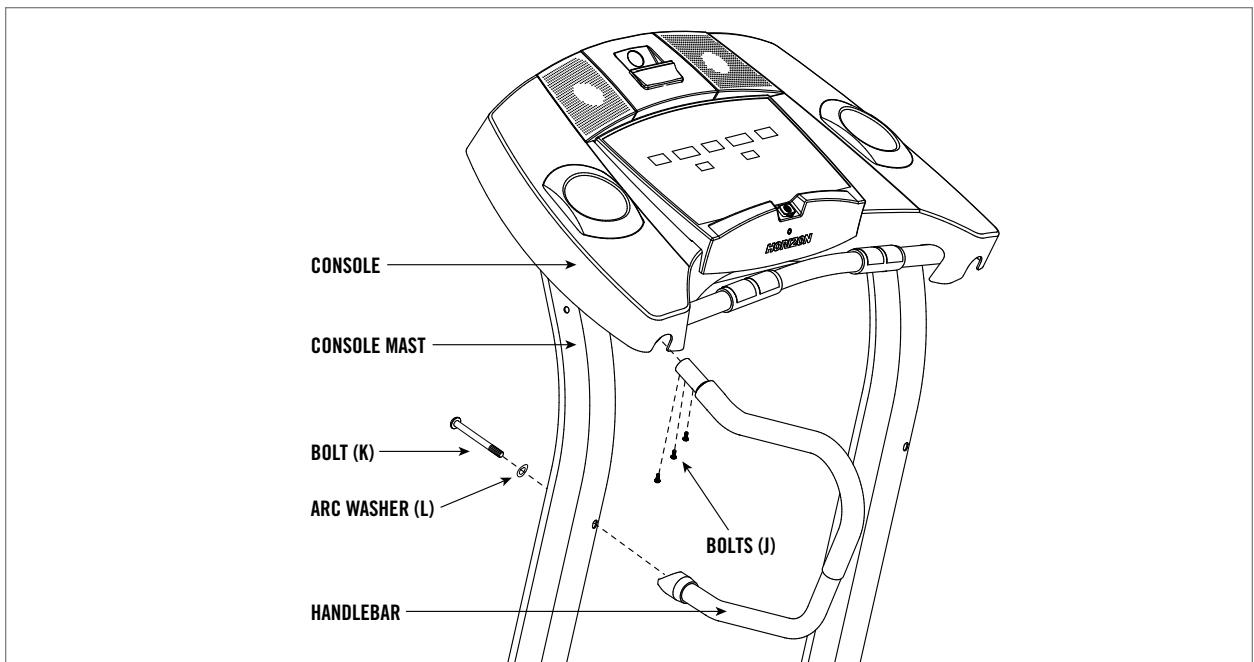

**A** Open **HARDWARE BAG 5**.

**B** Attach top of **LEFT HANDLEBAR** to **CONSOLE** using 3 **BOLTS (J)**.

**C** Attach bottom of **LEFT HANDLEBAR** to **CONSOLE MAST** using 1 **BOLT (K)** and 1 **ARC WASHER (L)**.

**D** Repeat on other side.

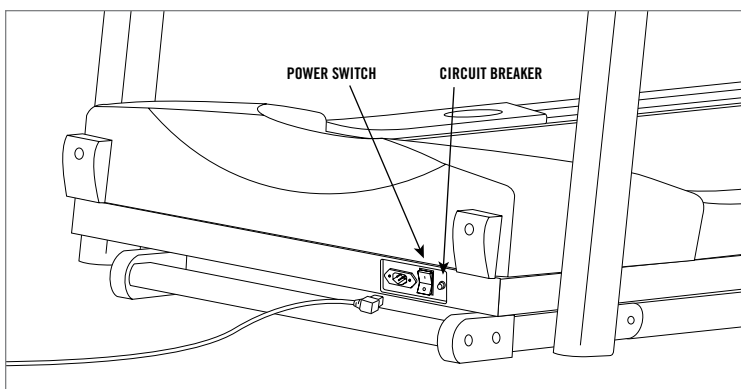

Connect power plug to the treadmill and connect the cord to a power outlet. The on/off switch is located next to the power cord. Flip this switch to the 'ON' position, so that the switch is lit. You will hear a beep and the console will light up.

**YOU'RE FINISHED!**

## BEFORE YOU BEGIN

**CONGRATULATIONS!** on choosing your treadmill. You've taken an important step in developing and sustaining an exercise program! Your treadmill is a tremendously effective tool for achieving your personal fitness goals. Regular use of your treadmill can improve the quality of your life in so many ways.

HERE ARE JUST A FEW OF THE HEALTH BENEFITS OF EXERCISE:

- Weight Loss
- A Healthier Heart
- Improved Muscle Tone
- Increased Daily Energy Levels

The key to reaping these benefits is to develop an exercise habit. Your new treadmill will help you eliminate obstacles that prevent you from exercising. Inclement weather and darkness won't interfere with your workout when you use your treadmill in the comfort of your home. This guide provides you with basic information for using and enjoying your new machine.

### LOCATION OF THE TREADMILL

Place the treadmill on a level surface. There should be 6 feet of clearance behind the treadmill, 3 feet on each side and one foot in front for folding and the power cord. Do not place the treadmill in any area that will block any vent or air openings. The treadmill should not be located in a garage, covered patio, near water or outdoors.

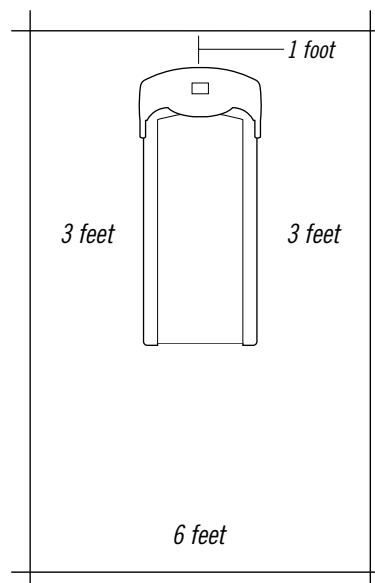

#### DO NOT STAND ON THE BELT

While you are preparing to use the treadmill, do not stand on the belt. Place your feet on the side rails before starting the treadmill. Start walking on the belt only after the belt has begun to move. Never start the treadmill at a fast running speed and attempt to jump on!

### SAFETY KEY

Your treadmill will not start unless the safety key is placed in position. Attach the clip end securely to your clothing. This safety key is designed to cut the power to the treadmill if you should fall. Check the operation of the safety key every 2 weeks.



**NEVER USE THE TREADMILL WITHOUT SECURING THE SAFETY KEY CLIP TO YOUR CLOTHING. PULL ON THE SAFETY KEY CLIP FIRST TO MAKE SURE IT WILL NOT COME OFF YOUR CLOTHING.**

## PROPER USAGE

Your treadmill is capable of reaching high speeds. Always start off using a slower speed and adjust the speed in small increments to reach a higher speed level. Never leave the treadmill unattended while it is running. When not in use, remove the safety key, turn the on/off switch to off and unplug the power cord. Make sure to follow the MAINTENANCE schedule located on page 33 in this manual. Keep your body and head facing forward. Do not attempt to turn around or look backwards while the treadmill is running. Stop your workout immediately if you feel pain, faint, dizzy or are short of breath.



**Do not operate the treadmill if the power cord or plug is damaged. If the treadmill appears to not be working properly, do not use the treadmill.**

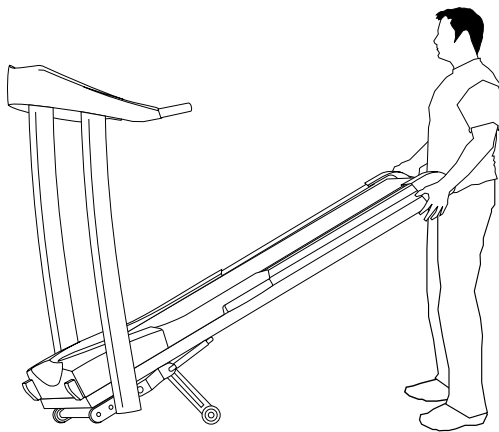

## FOLDING

Firmly grasp the back end of the treadmill. Carefully lift the end of the treadmill deck into the upright position until the foot lock latch engages and securely locks the deck into position. Make sure the deck is securely latched before letting go. To unfold, firmly grasp the back end of the treadmill. Gently press down on the foot lock latch with your foot until the lock latch disengages. Carefully lower the deck to the ground. **NOTE: The foot lock latch is located on the bottom right side of the deck.**

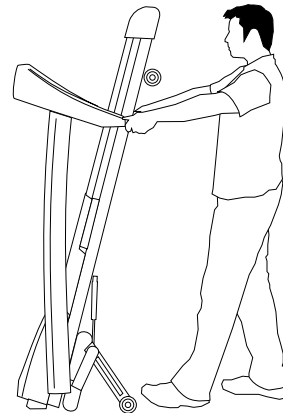

## MOVING

Your treadmill has a pair of transport wheels built into the frame. To move, make sure the treadmill is folded and securely latched. Then firmly grasp the handlebars, tilt the treadmill back and roll.



**Our Treadmills are heavy, use care and additional help if necessary when moving. Do not attempt to move or transport treadmill unless it is in the upright, folded position with the lock latch secured. Failure to follow these instructions could result in injury.**

## TENSIONING THE RUNNING BELT

The running belt has been properly adjusted at the factory before it was shipped. At times the belt can move off-center during shipment.

**CAUTION:** Running belt should NOT be moving during tensioning. Over-tightening the running belt can cause excessive wear on the treadmill as well as its components. Never over-tighten the belt.

If you can feel a slipping sensation when running on the treadmill, the running belt must be tightened. In most cases, the belt has stretched from use, causing the belt to slip. This is a normal and common adjustment. To eliminate this slipping, **TURN THE TREADMILL OFF** and tension **BOTH THE REAR ROLLER BOLTS** using the supplied Allen wrench, turning them 1/4 TURN to the right as shown. Turn the treadmill on and check for slipping. Repeat if necessary, but **NEVER TURN** the roller bolts more than 1/4 turn at a time. Belt is properly tensioned when the slipping sensation is gone.

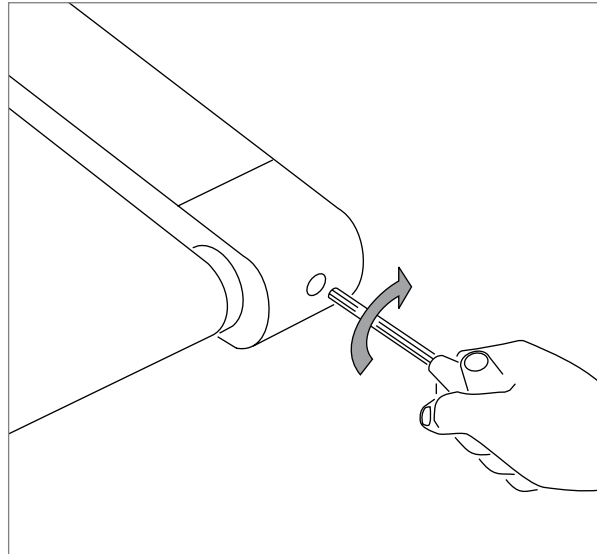
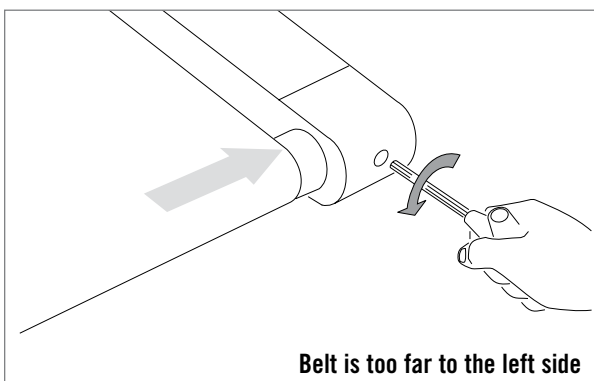
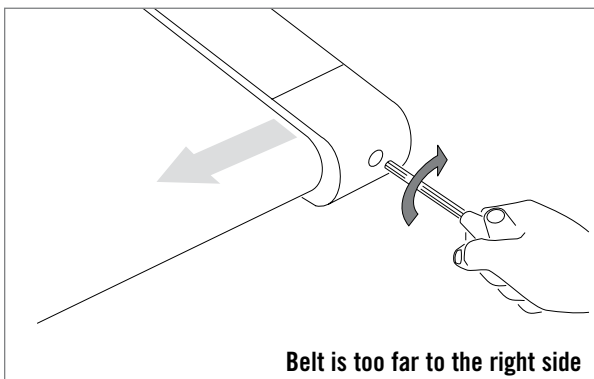

## CENTERING THE RUNNING BELT

The running belt has been properly adjusted at the factory before it was shipped. At times the belt can move off-center during shipment. Before operating the treadmill, make sure the belt is centered and remains centered to maintain smooth operation.

**CAUTION:** Do not run belt faster than 1/2 mph while centering. Keep fingers, hair and clothing away from belt at all times.

**If the running belt is too far to the right side:** With the treadmill running at 1/2 mph, turn the right adjustment bolt clockwise 1/4 TURN at a time (using the supplied Allen wrench). Check the belt alignment. Allow belt to run a full cycle to gauge if more adjustment is needed. Repeat if necessary, until the belt remains centered during use.

**If the running belt is too far to the left side:** With the treadmill running at 1/2 mph, turn the right adjustment bolt counter-clockwise 1/4 TURN at a time (using the supplied Allen wrench). Check the belt alignment. Allow belt to run a full cycle to gauge if more adjustment is needed. Repeat if necessary, until the belt remains centered during use.

# TREADMILL OPERATION

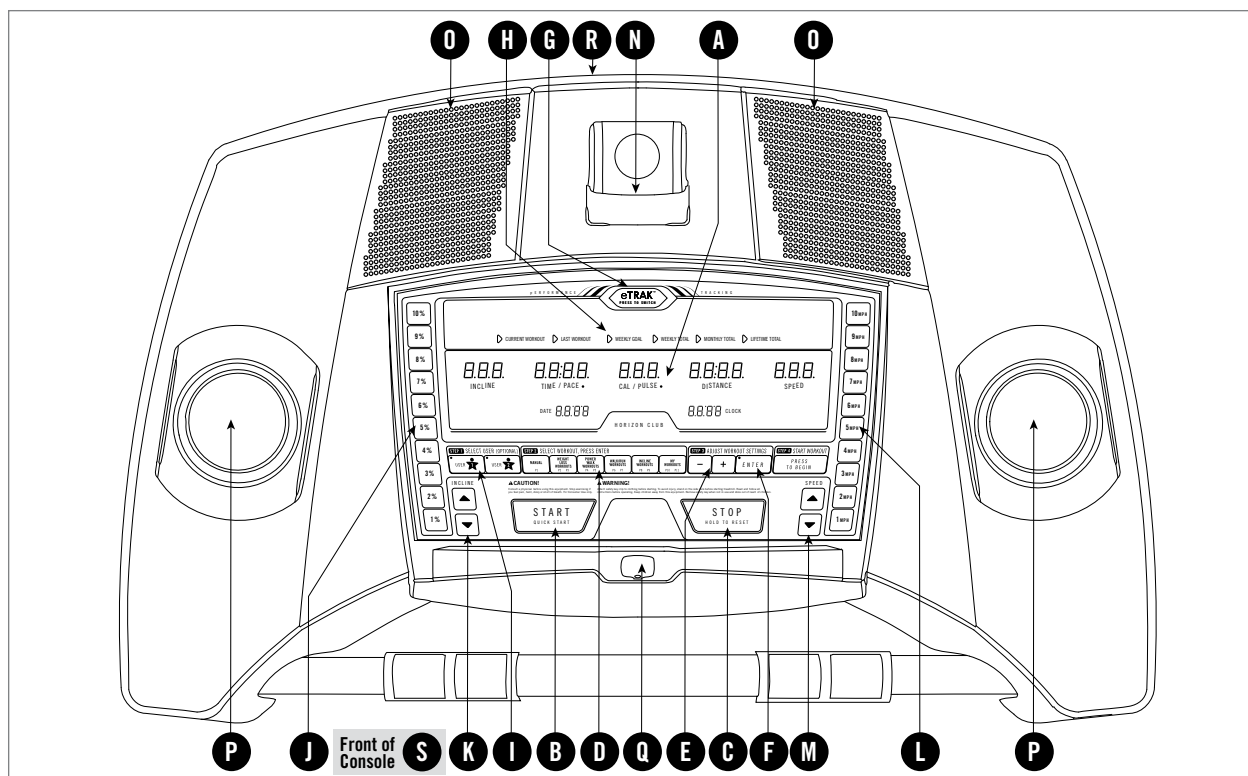

- A) MONITOR DISPLAY:** Incline, Time, Pace, Calories, Pulse, Distance and Speed.
- B) START/QUICK START:** Simply press to begin exercising.
- C) STOP:** Press to pause/end your workout. Hold for 3 seconds to reset the treadmill.
- D) QUICK WORKOUT KEYS:** Used to select a workout.
- E) WORKOUT SETTING KEYS:** Press to adjust Time, Incline and Speed.
- F) ENTER:** Used to select workout and confirm workout settings. Press to change display feedback during workout.
- G) eTRAK™ BUTTON:** Used to scroll through eTRAK™ display modes.
- H) eTRAK™ DISPLAY MODES:** Light indicates active eTRAK™ display mode.
- I) USER KEYS:** Press to select user.
- J) QUICK INCLINE KEYS:** Used to reach desired incline more quickly.
- K) INCLINE ARROW KEYS:** Used to adjust incline in small increments (0.5% increments).
- L) QUICK SPEED KEYS:** Used to reach desired speed more quickly.
- M) SPEED ARROW KEYS:** Used to adjust speed in small increments (0.1 mph increments).
- N) MP3 HOLDER:** Holds personal MP3 player.
- O) SPEAKERS:** Music plays through speakers when your CD / MP3 player is connected to the console.
- P) WATER BOTTLE / STORAGE COMPARTMENTS:** Holds personal workout equipment.
- Q) SAFETY KEY POSITION:** Enables treadmill operation when safety key is in place.
- R) AUDIO IN:** Plug your CD / MP3 player into the console using the included audio adaptor cable.
- S) AUDIO OUT / HEADPHONE JACK:** Plug your headphones into this jack to listen to your music through the headphones. **NOTE:** When headphones are plugged into the headphone jack the sound will no longer come out through the speakers.

## MONITOR DISPLAY

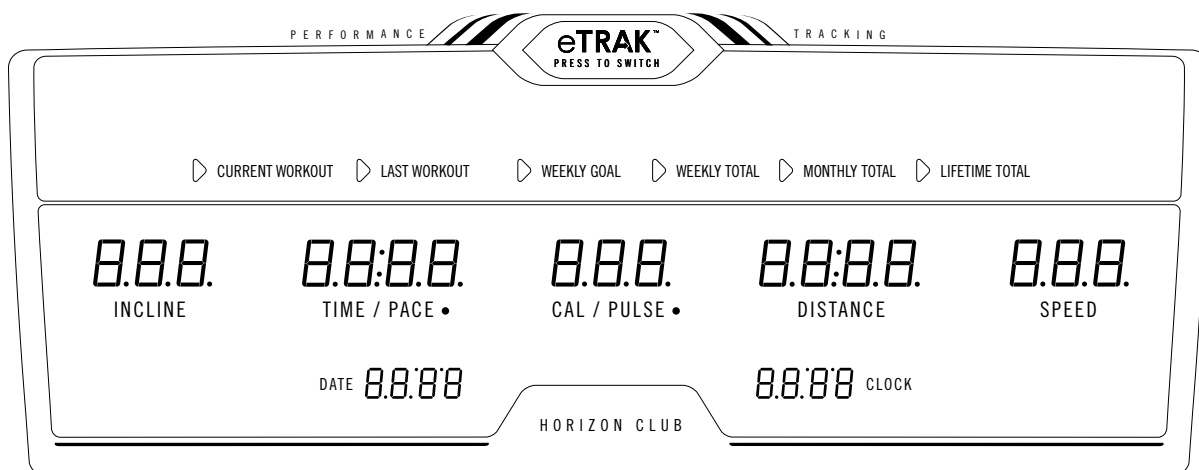

**INCLINE** • Shown as Percent. Indicates the incline of the treadmill deck surface.

**TIME** • Shown as Minutes:Seconds. Indicates the time remaining or the time elapsed in your workout.

**PACE** • Indicates how many minutes it takes to complete a mile while running or walking at your current speed. For example: If at your current speed it will take you 10 minutes to complete a mile, the treadmill will display '10:00' as your pace.

**GALORIES** • Indicates total Calories burned during your workout.

**PULSE** • Shown as Beats Per Minute. Indicates your heart rate (displayed when contact is made with both pulse grips).

**DISTANCE** • Shown as Miles. Indicates distance traveled during your workout.

**SPEED** • Shown as MPH. Indicates the speed of the treadmill belt.

## DATE & CLOCK SETUP

- 1) Enter Setup Mode: Press and hold **MANUAL** and **WEIGHT LOSS WORKOUTS** buttons for 3 seconds.
- 2) Once in setup mode, use the **WORKOUT SETTING + / - KEYS** to scroll through settings.
- 3) Use the **ENTER** button to confirm settings.
- 4) Settings include: MONTH, DAY, YEAR, HOUR, MINUTE, and AM/PM.
- 5) Review Settings: You can review your settings at any time while in Setup Mode. Use the **ENTER** button to scroll through settings.
- 6) Exit Setup Mode: To confirm the Date and Time, press and hold **ENTER** for 5 seconds.
- 7) To Reset: Simply re-enter Setup Mode and adjust Date and Time to the correct setting.



## HEART RATE

### **PULSE GRIPS**

Place the palm of your hands directly on the grip pulse handlebars. Both hands must grip the bars for your heart rate to register. It takes 5 consecutive heart beats (15-20 seconds) for your heart rate to register. When gripping the pulse handlebars, do not grip tightly. Holding the grips tightly may elevate your blood pressure. Keep a loose, cupping hold. You may experience an erratic readout if consistently holding the grip pulse handlebars. Make sure to clean the pulse sensors to ensure proper contact can be maintained.

## GETTING STARTED / SELECTING A WORKOUT

- 1) Check to make sure nothing is on or will hinder the movement of the treadmill.
- 2) Plug in the power cord and turn the treadmill ON.
- 3) Stand on the side rails of the treadmill.
- 4) Attach the safety key clip to part of your clothing.
- 5) Insert the safety key into the safety keyhole in the console.
- 6) You have two options to start your workout:
  - A) **QUICK START UP**  
Simply press the **START** key to begin working out. OR...
  - B) **SELECT A WORKOUT**  
Select a **WORKOUT** using the **QUICK WORKOUT KEYS**.  
Once a **WORKOUT** has been chosen, press **ENTER**.
  - C) **SELECT A TIME**  
Select a Time using the **WORKOUT SETTING KEYS** or use the default time.  
Once a **TIME** has been chosen, press **START**.

### **FINISHING YOUR WORKOUT**

When your workout is complete, the **MONITOR DISPLAY** will beep. Your workout information will stay displayed on the console for 30~45 seconds and then reset.

### **CLEAR CURRENT SELECTION**

To clear the current workout selection or screen, hold the **STOP** button for 3-5 seconds.

## WORKOUT INFORMATION

### WORKOUT: MANUAL (P1)

Allows 'On The Fly' manual **SPEED** and **INCLINE** changes. Time-based goal.

### WORKOUT: WEIGHT LOSS 1 & 2 (P2 & P3)

Challenges with various combinations of hills and valleys (**INCLINE & SPEED** levels).

#### WEIGHT LOSS 1 & 2 WORKOUT SEGMENTS (all segments last 30 seconds)

|                  |           | WARM-UP |     | 1   | 2   | 3   | 4   | 5   | 6   | 7   | 8   | SEGMENTS ARE REPEATED<br>UNTIL SELECTED TIME<br>IS REACHED | COOL-DOWN |     |
|------------------|-----------|---------|-----|-----|-----|-----|-----|-----|-----|-----|-----|--|-----------|-----|
| WEIGHT<br>LOSS 1 | Elevation | 0.5     | 1.0 | 2.0 | 2.0 | 1.5 | 1.0 | 1.0 | 1.0 | 1.5 | 2.0 |  | 1.0       | 0.5 |
|                  | Speed     | 1.5     | 2.3 | 3.0 | 3.5 | 4.0 | 4.5 | 5.0 | 4.5 | 4.0 | 3.5 |  | 3.0       | 2.0 |
| WEIGHT<br>LOSS 2 | Elevation | 1.0     | 1.5 | 2.5 | 2.5 | 2.0 | 1.5 | 1.5 | 1.5 | 2.0 | 2.5 |  | 1.5       | 1.0 |
|                  | Speed     | 2.3     | 3.4 | 4.5 | 5.0 | 5.5 | 6.0 | 6.5 | 6.0 | 5.5 | 5.0 | 4.1  | 2.8       |     |

(WARM-UP and COOL-DOWN last 4:00 minutes each and are included in workout times)

### WORKOUT: POWER WALK 1 & 2 (P4 & P5)

Motivates with different combinations of **SPEED**.

#### POWER WALK 1 & 2 WORKOUT SEGMENTS (all segments last 30 seconds)

|              |  | WARM-UP |     | 1   | 2   | 3   | 4   | 5   | 6   | 7   | 8   | SEGMENTS ARE<br>REPEATED UNTIL<br>SELECTED TIME<br>IS REACHED | COOL-DOWN |     |
|--------------|--|---------|-----|-----|-----|-----|-----|-----|-----|-----|-----|---|-----------|-----|
| POWER WALK 1 |  | 1.0     | 1.5 | 2.0 | 2.5 | 3.0 | 3.5 | 4.0 | 3.5 | 3.0 | 2.5 |   | 2.3       | 1.5 |
| POWER WALK 2 |  | 1.5     | 2.3 | 3.0 | 3.5 | 4.0 | 4.5 | 5.0 | 4.5 | 4.0 | 3.5 |   | 3.0       | 2.0 |

(WARM-UP and COOL-DOWN last 4:00 minutes each and are included in workout times)

**WORKOUT: WALK / RUN 1 & 2 (P6 & P7)**

Walk and run a series of alternating **SPEED** levels.

**WALK / RUN 1 & 2 WORKOUT SEGMENTS** (valley segments last 90 seconds, peak segments last 30 seconds)

|                     | WARM-UP             |     | 1   | 2   | 3   | 4   | SEGMENTS ARE REPEATED UNTIL SELECTED TIME IS REACHED | COOL-DOWN |     |
|---------------------|---------------------|-----|-----|-----|-----|-----|--|-----------|-----|
|                     | <b>WALK / RUN 1</b> | 1.3 | 1.9 | 2.5 | 5.5 | 2.5 |  | 5.5       | 1.9 |
| <b>WALK / RUN 2</b> | 1.5                 | 2.3 | 3.0 | 6.5 | 3.0 | 6.5 | 2.3  | 1.5       |     |

(WARM-UP and COOL-DOWN last 4:00 minutes each and are included in workout times)

**WORKOUT: INCLINE 1 & 2 (P8 & P9)**

Simulates climbing and descending a mountain by automatically varying **INCLINE**.

**INCLINE 1 & 2 WORKOUT SEGMENTS** (all segments last 30 seconds)

|                  | WARM-UP          |     | 1   | 2   | 3   | 4   | 5   | 6   | 7   | 8   | 9   | 10  | SEGMENTS ARE REPEATED UNTIL SELECTED TIME IS REACHED | COOL-DOWN |     |
|------------------|------------------|-----|-----|-----|-----|-----|-----|-----|-----|-----|-----|-----|--|-----------|-----|
|                  | <b>INCLINE 1</b> | 0.0 | 1.5 | 2.5 | 3.0 | 3.5 | 4.0 | 4.5 | 4.5 | 4.0 | 3.5 | 3.0 |  | 2.5       | 1.5 |
| <b>INCLINE 2</b> | 0.0              | 1.5 | 4.0 | 4.5 | 5.0 | 5.5 | 6.0 | 6.0 | 5.5 | 5.0 | 4.5 | 4.0 | 1.5  | 0.0       |     |

(WARM-UP and COOL-DOWN last 4:00 minutes each and are included in workout times)

## WORKOUT: MY WORKOUT 1 & 2 (P10 & P11)

Lets you create and reuse a perfect workout for you with specific speed, incline and time combination. The ultimate in personal programming. Time-based goal.

- 1) Once the **MY WORKOUT 1** or **2** program has been chosen, press **ENTER**.
- 2) Choose the desired **TIME** using the **WORKOUT SETTING KEYS** and press **ENTER**.
- 3) Choose the desired **SPEED** for each segment, using the **WORKOUT SETTING KEYS** and press **ENTER**. Note: There are 15 segments and you will need to press **ENTER** after each segment.
- 4) Choose the desired **INCLINE** for each segment, using the **WORKOUT SETTING KEYS** and press **ENTER**. Note: There are 15 segments and you will need to press **ENTER** after each segment.
- 5) Press **START** to begin your workout. At this time, your workout has been successfully saved into memory, and can be used for future workouts.
  - To **RESET** your workout information and delete it from memory, select **MY WORKOUT 1** or **2** program, press **ENTER**, then press and hold the **ENTER** key for 5 seconds.
  - While using your saved program, you are able to adjust the speed or incline, but any changes will not be saved.

## WORKOUT INFORMATION

### USING eTRAK™ PERFORMANCE TRACKER

#### INTRODUCTION

Research shows that those who journal their fitness routines or workouts, on average, achieve greater success than those who do not. Because your new treadmill is equipped with Horizon's exclusive eTRAK™ Performance Tracker, you've taken an important step towards achieving your fitness goals. Congratulations!

eTRAK™ is an innovative new software, integrated into your treadmill console, that will allow you to track your fitness progress over time, without the need for paper journals or logs. eTRAK™ allows you to easily compare your current workout to your last, average or lifetime workout totals. With quick access to feedback like time of workout or calories burned during previous workouts, you'll be able to quickly and easily see the progress you've made. Read further to learn about how eTRAK™ can help motivate you to enhance your performance.

## eTRAK™ OPERATION

**SETUP:** To activate eTRAK™ a user **MUST** be chosen before the program begins. To select a user, simply press the User 1 or User 2 button. To deselect a user, press User button again. All accumulated data specifically relates to the user that is chosen. **NOTE:** If no user is selected, no data will be tracked.

**RESET:** Reset all recorded information for User 1 or User 2 by selecting the user and then holding down the user button for 10 seconds. **NOTE:** This step is permanent and will delete ALL previously accumulated data for the chosen user.

**ACCUMULATED DATA:** Once a **USER** is chosen, eTRAK™ is activated and you can scroll through your accumulated data in multiple formats by pressing the eTRAK™ button. A workout is saved when: the program ends, the console is paused and not resumed within 10 minutes, or the Stop button is held to reset the console.

- 1) **CURRENT WORKOUT:** The console automatically defaults to Current Workout, displaying your progress in real time.
- 2) **LAST WORKOUT:** This option allows you to view your accumulated data from your last workout. The Current Workout becomes the Last Workout once a program has ended or the console has been reset. The following information will be shown in each display window:
  - INCLINE** - Average incline of last workout.
  - SPEED** - Average speed of last workout.
  - TIME** - Total time of last workout.
  - DISTANCE** - Total distance of last workout.
  - CALORIES** - Total calories burned during last workout.
- 3) **WEEKLY GOAL:** This option allows you to set and view your weekly time or distance goal based on a calendar week and will run concurrently with the WEEKLY TOTAL function. The following information will be shown in each display window:
  - CLOCK/DATE** – “GOAL” - Indicates the weekly goal you set. “LEFT” - Indicates the time or distance you have left to complete to meet your weekly goal. When the goal is complete, the CLOCK/DATE will show “GOAL DONE”.
  - TIME** or **DISTANCE** – The total time or distance goal you selected and the time or distance you have left to complete to meet your weekly goal.

**NOTE:**

1. The “GOAL” and “LEFT” will display alternately every 3 seconds.
2. If the date and clock are not set and/or a weekly goal is not set, WEEKLY GOAL will display zeros.
3. The time or distance left for the Weekly Goal will reset at the end of each week.

- 4) **WEEKLY TOTAL:** View your accumulated data from the last Sunday to the present day. *NOTE: This data is based on week to date NOT the previous seven days. For instance, if you have not used the machine since Sunday, the console will read zeros. The following information will be shown in each display window:*

*INCLINE* - Average incline of weekly workouts.  
*SPEED* - Average speed of weekly workouts.  
*TIME* - Total time of weekly workout.  
*DISTANCE* - Total distance of weekly workouts.  
*CALORIES* - Average weekly calories burned.

*NOTE: If the Date and Clock are not set, Weekly Total will default to the Last Workout data.*

- 5) **MONTHLY TOTAL:** View your accumulated data from the first day of the month to the present day. *NOTE: This data is based on month to date NOT the previous thirty days. For instance, if you have not used the machine since the first of the month, the console will read zeros. The following information will be shown in each display window:*

*INCLINE* - Average incline of monthly workouts.  
*SPEED* - Average speed of monthly workouts.  
*TIME* - Total time of monthly workout.  
*DISTANCE* - Total distance of monthly workouts.  
*CALORIES* - Average monthly calories burned.

*NOTE: If the Date and Clock are not set, Monthly Total will default to equal the Last Workout data.*

- 6) **LIFETIME TOTAL:** This option allows you to view the total accumulated data from your first workout to your last saved workout. The following information will be shown in each display window:

*INCLINE* - Average incline.  
*SPEED* - Average speed.  
*TIME* - Total accumulated time. *NOTE: If time is greater than 59:59, the time will no longer display minutes and will display hours only.*  
*DISTANCE* - Total accumulated distance.  
*CALORIES* - Average calories burned.

## WEEKLY GOAL SETUP

- 1) Select **USER 1** or **USER 2**.
- 2) Press **eTRAK™** button and scroll to **WEEKLY GOAL**.
- 3) Enter the Setup Mode: Press **ENTER**. Use **+/- KEYS** to set a time goal (leave time at 0:00 if you want to set a distance goal).
- 4) Press **ENTER** button again and use the **+/- KEYS** to set a distance goal. If the distance is changed from 0.00, distance will be the goal.  
*Note: You may only set a time or distance goal, not both.*
- 5) Press **ENTER** button again to exit the **SETUP MODE**.

# CONDITIONING GUIDELINES

*ALWAYS CONSULT YOUR PHYSICIAN BEFORE BEGINNING AN EXERCISE PROGRAM.*

## **HOW OFTEN? (Frequency of Workouts)**

*The American Heart Association recommends that you exercise at least 3 to 4 days per week to maintain cardiovascular fitness. If you have other goals such as weight or fat loss, you will achieve your goal faster with more frequent exercise. Whether it's 3 days or 6 days, remember that your ultimate goal should be to make exercise a lifetime habit. Many people are successful staying with a fitness program if they set aside a specific time of day to exercise. It doesn't matter whether it's in the morning before breakfast, during lunch hour or while watching the evening news. What's more important is that it's a time that allows you to keep a schedule, and a time when you won't be interrupted. To be successful with your fitness program, you have to make it a priority in your life. So decide on a time, pull out your day planner and pencil in your exercise times for the next month!*

## **HOW LONG? (Duration of Workouts)**

*For aerobic exercise benefits, it's recommended that you exercise from between 24 and 60 minutes per session. But start slowly and gradually increase your exercise times. If you've been sedentary during the past year, it may be a good idea to keep your exercise times to as little as five minutes initially. Your body will need time to adjust to the new activity. If your goal is weight loss, a longer exercise session at lower intensities has been found to be most effective. A workout time of 48 minutes or more is recommended for best weight loss results.*

## **HOW HARD? (Intensity of Workouts)**

*How hard you workout is also determined by your goals. If you use your treadmill to prepare for a 5K run, you will probably work out at a higher intensity than if your goal is general fitness. Regardless of your long term goals, always begin an exercise program at low intensity. Aerobic exercise does not have to be painful to be beneficial! There are two ways to measure your exercise intensity. The first is by monitoring your heart rate using the grip pulse handlebars, and the second is by evaluating your perceived exertion level (this is simpler than it sounds!).*

## **PERCEIVED EXERTION LEVEL**

*A simple way to gauge your exercise intensity is to evaluate your perceived exertion level. While exercising, if you are too winded to maintain a conversation without gasping, you are working out too hard. A good rule of thumb is to work to the point of exhilaration, not exhaustion. If you cannot catch your breath, it's time to slow down. Always be aware of these warning signs of overexertion.*

## TARGET HEART RATE ZONE CHART

### What is Target Heart Rate Zone?

Target Heart Rate Zone tells you the number of times per minute your heart needs to beat to achieve a desired workout effect. It is represented as a percentage of the maximum number of times your heart can beat per minute. Target Zone will vary for each individual, depending on age, current level of conditioning, and personal fitness goals. The American Heart Association recommends working-out at a Target Heart Rate Zone of between 60% and 75% of your maximum heart rate. A beginner will want to workout in the 60% range while a more experienced exerciser will want to workout in the 70-75% range. See chart for reference.

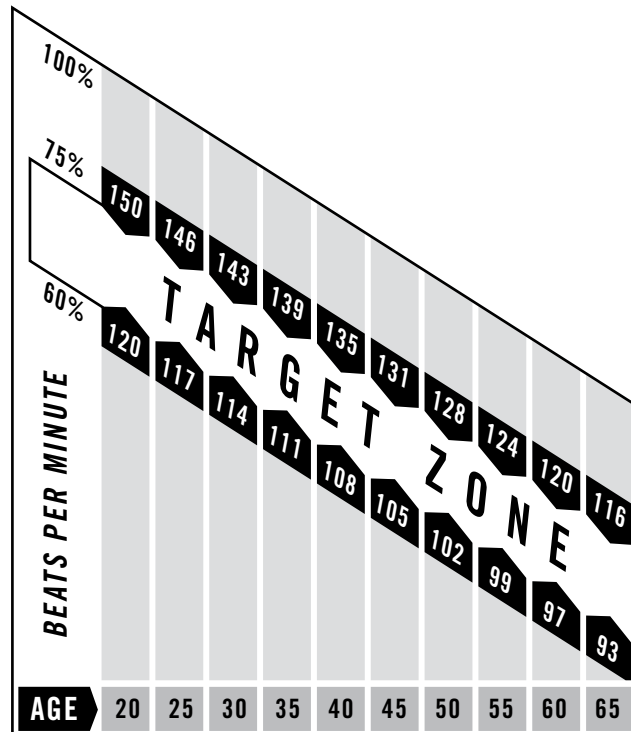

### EXAMPLE:

For a 42-year-old user: Find age along the bottom of the chart (round to 40), follow age column up to the target zone bar. Results: 60% of maximum Heart Rate = 108 Beats Per Minute, 75% of maximum Heart Rate = 135 Beat Per Minute.

**ALWAYS CONSULT YOUR PHYSICIAN BEFORE BEGINNING AN EXERCISE PROGRAM.**



**TIPS** **STRETCHING****STRETCH FIRST**

Before using your product, it is best to take a few minutes doing a few gentle stretching exercises. Stretching prior to exercise will improve flexibility and reduce chances of exercise related injury. Ease into each of these stretches with a slow gentle motion. Do not stretch to the point of pain. Make sure not to bounce while doing these stretches.

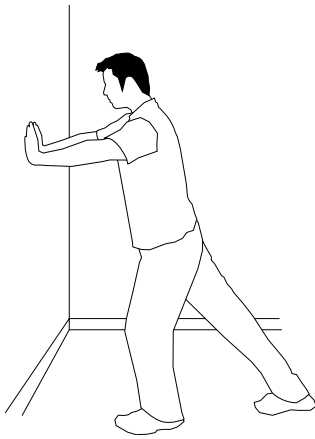
**1. STANDING CALF MUSCLE STRETCH**

Stand near a wall with the toes of your left foot about 18" from the wall, and the right foot about 12" behind the other foot. Lean forward, pushing against the wall with your palms. Keep your heels flat and hold this position for a count of 15 seconds. Make sure that you do not bounce while stretching. Repeat on the other side.

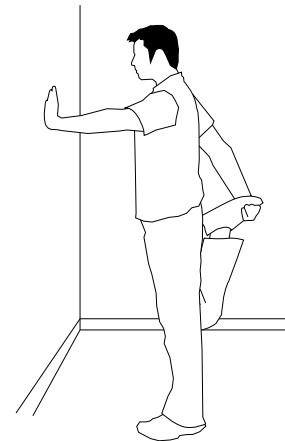
**2. STANDING QUADRICEP STRETCH**

Using a wall to provide balance, grasp your left ankle with your left hand and hold your foot against the back of your thigh for 15 seconds. Repeat with your right ankle and hand.

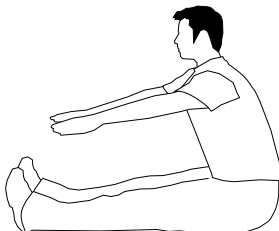
**3. SITTING HAMSTRING & LOWER BACK MUSCLE STRETCH**

Sit on the floor with your legs together and straight out in front of you. Do not lock your knees. Extend your fingers towards your toes and hold for a count of 15 seconds. Make sure that you do not bounce while stretching. Sit upright again. Repeat one time.

**TIPS****THE IMPORTANCE OF WARM UP & COOL DOWN****WARM UP**

The first 2 to 5 minutes of a workout should be devoted to warming up. The warm-up will limber your muscles and prepare them for more strenuous exercise. Make sure that you warm-up on your product at a slow pace. The warm up should gradually bring your heart rate into your Target Heart Rate Zone.

**COOL DOWN**

Never stop exercising suddenly! A cool-down period of 3-5 minutes allows your heart to readjust to the decreased demand. Make sure that your cool down period consists of a very slow pace to allow your heart rate to lower. After the cool-down, repeat the stretching exercises listed above to loosen and relax your muscles.

**TIPS****ACHIEVING YOUR FITNESS GOALS**

An important step in developing a long term fitness program is to determine your goals. Is your primary goal for exercising to lose weight? Improve muscle? Reduce stress? Prepare for the spring racing schedule? Knowing what your goals are will help you develop a more successful exercise program. Below are some common exercise goals:

- *Weight Loss - lower intensity, longer duration workouts*
- *Improve Body Shape and Tone - interval workouts, alternate between hi and low intensities*
- *Increased Energy Level - more frequent daily workouts*
- *Improved Sports Performance - high intensity workouts*
- *Improved Cardiovascular Endurance - moderate intensity, longer duration workouts*

If possible try to define your personal goals in precise, measurable terms, and then put your goals in writing. The more specific you can be, the easier it will be to track your progress. If your goals are long term, divide them up into monthly and weekly segments. Longer term goals can lose some of the immediate motivation benefits. Short term goals are easier to achieve. Your console provides you with several readouts that can be used to record your progress. You can track Distance, Calories or Time.

**KEEPING AN EXERCISE DIARY**

To make your personal exercise log book, photocopy the weekly and monthly log sheets, which are located on the following pages, or you can print them off of your computer by going to:

[www.horizonfitness.com/guides/weeklylog.pdf](http://www.horizonfitness.com/guides/weeklylog.pdf)

[www.horizonfitness.com/guides/monthlylog.pdf](http://www.horizonfitness.com/guides/monthlylog.pdf)

As your fitness improves, you can look back and see how far you've come!

# WEEKLY LOG SHEETS

| <b>WEEK #</b> _____    |             | <b>WEEKLY GOAL</b> _____ |                 |             |                 |
|------------------------|-------------|--------------------------|-----------------|-------------|-----------------|
| <b>DAY</b>             | <b>DATE</b> | <b>DISTANCE</b>          | <b>CALORIES</b> | <b>TIME</b> | <b>COMMENTS</b> |
| <i>SUNDAY</i>          |             |                          |                 |             |                 |
| <i>MONDAY</i>          |             |                          |                 |             |                 |
| <i>TUESDAY</i>         |             |                          |                 |             |                 |
| <i>WEDNESDAY</i>       |             |                          |                 |             |                 |
| <i>THURSDAY</i>        |             |                          |                 |             |                 |
| <i>FRIDAY</i>          |             |                          |                 |             |                 |
| <i>SATURDAY</i>        |             |                          |                 |             |                 |
| <b>WEEKLY TOTALS :</b> |             |                          |                 |             |                 |

| <b>WEEK #</b> _____    |             | <b>WEEKLY GOAL</b> _____ |                 |             |                 |
|------------------------|-------------|--------------------------|-----------------|-------------|-----------------|
| <b>DAY</b>             | <b>DATE</b> | <b>DISTANCE</b>          | <b>CALORIES</b> | <b>TIME</b> | <b>COMMENTS</b> |
| <i>SUNDAY</i>          |             |                          |                 |             |                 |
| <i>MONDAY</i>          |             |                          |                 |             |                 |
| <i>TUESDAY</i>         |             |                          |                 |             |                 |
| <i>WEDNESDAY</i>       |             |                          |                 |             |                 |
| <i>THURSDAY</i>        |             |                          |                 |             |                 |
| <i>FRIDAY</i>          |             |                          |                 |             |                 |
| <i>SATURDAY</i>        |             |                          |                 |             |                 |
| <b>WEEKLY TOTALS :</b> |             |                          |                 |             |                 |

| <b>WEEK #</b> _____    |             | <b>WEEKLY GOAL</b> _____ |                 |             |                 |
|------------------------|-------------|--------------------------|-----------------|-------------|-----------------|
| <b>DAY</b>             | <b>DATE</b> | <b>DISTANCE</b>          | <b>CALORIES</b> | <b>TIME</b> | <b>COMMENTS</b> |
| <i>SUNDAY</i>          |             |                          |                 |             |                 |
| <i>MONDAY</i>          |             |                          |                 |             |                 |
| <i>TUESDAY</i>         |             |                          |                 |             |                 |
| <i>WEDNESDAY</i>       |             |                          |                 |             |                 |
| <i>THURSDAY</i>        |             |                          |                 |             |                 |
| <i>FRIDAY</i>          |             |                          |                 |             |                 |
| <i>SATURDAY</i>        |             |                          |                 |             |                 |
| <b>WEEKLY TOTALS :</b> |             |                          |                 |             |                 |

INTRODUCTION

IMPORTANT PRECAUTIONS

ASSEMBLY

BEFORE YOU BEGIN

TREADMILL OPERATION

CONDITIONING GUIDELINES

TROUBLESHOOTING & MAINTENANCE

LIMITED WARRANTY

| <b>WEEK #</b> _____    |             | <b>WEEKLY GOAL</b> _____ |                 |             |                 |
|------------------------|-------------|--------------------------|-----------------|-------------|-----------------|
| <b>DAY</b>             | <b>DATE</b> | <b>DISTANCE</b>          | <b>CALORIES</b> | <b>TIME</b> | <b>COMMENTS</b> |
| <i>SUNDAY</i>          |             |                          |                 |             |                 |
| <i>MONDAY</i>          |             |                          |                 |             |                 |
| <i>TUESDAY</i>         |             |                          |                 |             |                 |
| <i>WEDNESDAY</i>       |             |                          |                 |             |                 |
| <i>THURSDAY</i>        |             |                          |                 |             |                 |
| <i>FRIDAY</i>          |             |                          |                 |             |                 |
| <i>SATURDAY</i>        |             |                          |                 |             |                 |
| <b>WEEKLY TOTALS :</b> |             |                          |                 |             |                 |

| <b>WEEK #</b> _____    |             | <b>WEEKLY GOAL</b> _____ |                 |             |                 |
|------------------------|-------------|--------------------------|-----------------|-------------|-----------------|
| <b>DAY</b>             | <b>DATE</b> | <b>DISTANCE</b>          | <b>CALORIES</b> | <b>TIME</b> | <b>COMMENTS</b> |
| <i>SUNDAY</i>          |             |                          |                 |             |                 |
| <i>MONDAY</i>          |             |                          |                 |             |                 |
| <i>TUESDAY</i>         |             |                          |                 |             |                 |
| <i>WEDNESDAY</i>       |             |                          |                 |             |                 |
| <i>THURSDAY</i>        |             |                          |                 |             |                 |
| <i>FRIDAY</i>          |             |                          |                 |             |                 |
| <i>SATURDAY</i>        |             |                          |                 |             |                 |
| <b>WEEKLY TOTALS :</b> |             |                          |                 |             |                 |

| <b>WEEK #</b> _____    |             | <b>WEEKLY GOAL</b> _____ |                 |             |                 |
|------------------------|-------------|--------------------------|-----------------|-------------|-----------------|
| <b>DAY</b>             | <b>DATE</b> | <b>DISTANCE</b>          | <b>CALORIES</b> | <b>TIME</b> | <b>COMMENTS</b> |
| <i>SUNDAY</i>          |             |                          |                 |             |                 |
| <i>MONDAY</i>          |             |                          |                 |             |                 |
| <i>TUESDAY</i>         |             |                          |                 |             |                 |
| <i>WEDNESDAY</i>       |             |                          |                 |             |                 |
| <i>THURSDAY</i>        |             |                          |                 |             |                 |
| <i>FRIDAY</i>          |             |                          |                 |             |                 |
| <i>SATURDAY</i>        |             |                          |                 |             |                 |
| <b>WEEKLY TOTALS :</b> |             |                          |                 |             |                 |

# MONTHLY LOG SHEETS

| <i>MONTH</i> _____             | <i>MONTHLY GOAL</i> _____ |                 |             |
|--------------------------------|---------------------------|-----------------|-------------|
| <i>WEEK #</i>                  | <i>DISTANCE</i>           | <i>CALORIES</i> | <i>TIME</i> |
|                                |                           |                 |             |
|                                |                           |                 |             |
|                                |                           |                 |             |
|                                |                           |                 |             |
|                                |                           |                 |             |
|                                |                           |                 |             |
|                                |                           |                 |             |
| <b><i>MONTHLY TOTALS :</i></b> |                           |                 |             |

| <i>MONTH</i> _____             | <i>MONTHLY GOAL</i> _____ |                 |             |
|--------------------------------|---------------------------|-----------------|-------------|
| <i>WEEK #</i>                  | <i>DISTANCE</i>           | <i>CALORIES</i> | <i>TIME</i> |
|                                |                           |                 |             |
|                                |                           |                 |             |
|                                |                           |                 |             |
|                                |                           |                 |             |
|                                |                           |                 |             |
|                                |                           |                 |             |
|                                |                           |                 |             |
|                                |                           |                 |             |
| <b><i>MONTHLY TOTALS :</i></b> |                           |                 |             |

| <i>MONTH</i> _____             | <i>MONTHLY GOAL</i> _____ |                 |             |
|--------------------------------|---------------------------|-----------------|-------------|
| <i>WEEK #</i>                  | <i>DISTANCE</i>           | <i>CALORIES</i> | <i>TIME</i> |
|                                |                           |                 |             |
|                                |                           |                 |             |
|                                |                           |                 |             |
|                                |                           |                 |             |
|                                |                           |                 |             |
|                                |                           |                 |             |
|                                |                           |                 |             |
|                                |                           |                 |             |
| <b><i>MONTHLY TOTALS :</i></b> |                           |                 |             |

INTRODUCTION

IMPORTANT PRECAUTIONS

ASSEMBLY

BEFORE YOU BEGIN

TREADMILL OPERATION

CONDITIONING GUIDELINES

TROUBLESHOOTING & MAINTENANCE

LIMITED WARRANTY

## COMMON PRODUCT QUESTIONS

### ARE THE SOUNDS MY TREADMILL MAKES NORMAL?

All treadmills make a certain type of thumping noise due to the belt riding over the rollers, especially new treadmills. This noise will diminish over time, although may not totally go away. Over time, the belt will stretch, causing the belt to ride smoother over the rollers.

### WHY IS THE TREADMILL I PURCHASED LOUDER THAN THE ONE AT THE STORE?

All fitness products seem quieter in a large store showroom because there is generally more background noise than in your home. Also, there will be less reverberation on a carpeted concrete floor than on a wood overlay floor. Sometimes a heavy rubber mat will help reduce reverberation through the floor. If a fitness product is placed close to a wall, there will be more reflected noise.

### WHEN SHOULD I BE WORRIED ABOUT A NOISE?

As long as the sounds your treadmill makes are no louder than a normal conversational tone of voice, it is considered normal noise.

## TROUBLESHOOTING - TREADMILL

Your treadmill is designed to be reliable and easy to use. However, if you experience a problem, please reference the troubleshooting guide listed below.

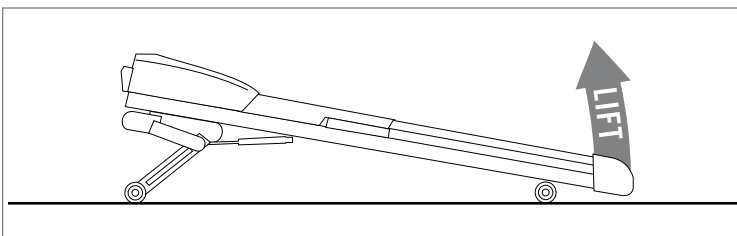

**PROBLEM:** The banding straps were removed before **ASSEMBLY STEP 2-D** was complete and the machine has sprung open and cannot be assembled.

**SOLUTION:** The air shocks have been engaged prematurely. To correct this, tilt the machine on its nose by lifting the deck (light end) upwards. Fold down the deck so that it is horizontal. You may now proceed with the assembly.

**PROBLEM:** The console does not light up and/or the belt does not move.

**SOLUTION:** Verify the following:

#### DOES THE RED LIGHT ON THE ON/OFF SWITCH LIGHT UP?

##### IF YES:

- Double check that all connections are secure, especially the console cable. Unplug and reconnect the console cable to verify.
- Make sure the console cable is not pinched or damaged in any way.
- Turn the power off, unplug the power cable and wait 60 seconds. Remove motor cover. Wait until all red LED lights have gone off on the motor control board before proceeding. Next, verify that none of the wires connected to the lower board are loose or disconnected.

##### IF NO:

- Verify that the outlet the machine is plugged into is functional. Double check that the breaker has not tripped, it is on a dedicated 20-amp circuit, it is not on a GFCI-equipped outlet, and it is not plugged into a power strip/surge protector or extension cord.
- The power cord is not pinched or damaged and is properly plugged into the outlet AND the machine.
- The power switch is turned to the ON position.

**PROBLEM:** The treadmill circuit breaker trips during a workout.

**SOLUTION:** Verify the following:

- Make sure the treadmill is plugged into a dedicated 20-amp circuit.
- Verify that you do not have the machine on an extension cord or surge protector.
- Confirm that the machine is not plugged into a GFCI-equipped outlet or on a circuit that has a GFCI-equipped outlet on it.
- Lubricate treadmill deck if necessary.

**PROBLEM:** The running belt does not stay centered during a workout.

**SOLUTION:** Verify the following:

- Make sure the treadmill is on a level surface.
- Verify that the belt is properly tightened and centered (Refer to the Adjustment section for detailed directions).

**PROBLEM:** Operating speed appears inaccurate.

**SOLUTION:** Auto-calibrate the treadmill:

- Power on the treadmill and have the safety key in position on the console. Press and hold the elevation “+” and speed “-” buttons for approximately 5 seconds to enter the Engineering Mode. The console will beep and “ENGO” appears in the display.
- Press the Speed “+” or “-” button until “ENG2” appears in the display.
- Press, “ENTER” to select. Press, “START” to begin. The treadmill running belt will begin to move automatically and the auto-calibration sequence will properly set and store the speed values.
- Upon successful calibration, the treadmill will beep several times. The console will automatically exit Engineering Mode and return to the start-up screen.



**DO NOT** stand on running belt while calibrating – stand on the guide rails. Treadmill will fluctuate between low and high speeds for several minutes until calibration is complete.

## TROUBLESHOOTING - HEART RATE

Check your exercise environment for sources of interference such as fluorescent lights, computers, underground fencing, home security systems or appliances containing large motors. These items may cause erratic heart rate readouts.

You may experience an erratic readout under the following conditions:

- Gripping the heart rate handlebars too tight. Try to maintain moderate pressure while holding onto the heart rate handlebars.
- Constant movement and vibration due to constantly holding the heart rate handlebars while exercising. If you are receiving erratic heart rate readouts, try to only hold the grips long enough to monitor your heart rate.
- When you are breathing heavily during a workout.
- When your hands are constricted by wearing a ring.
- When your hands are dry or cold. Try to moisten your palms by rubbing them together to warm.
- Anyone with heavy arrhythmia.
- Anyone with arteriosclerosis or peripheral circulation disorder.
- Anyone whose skin on the measuring palm is especially thick.

If the above troubleshooting section does not remedy the problem, discontinue use and turn the power off.

**PLEASE CALL CUSTOMER TECH SUPPORT AT THE NUMBER ON THE BACK PANEL.**

The following information may be asked of you when you call. Please have these items readily available:

- Model Name
- Serial Number
- Date of Purchase (receipt or credit card statement)

In order for Customer Tech Support to service your treadmill they may need to ask detailed questions about the symptoms that are occurring. Some troubleshooting questions that may be asked are:

- How long has this problem been occurring?
- Does this problem occur with every use? With every user?
- If you are hearing a noise, does it come from the front or the back? What kind of noise is it (thumping, grinding, squeaking, chirping etc.)?
- Has the machine been lubricated and maintained per the maintenance schedule?

Answering these and other questions will give the technicians the ability to send proper replacement parts and the service necessary to get you and your Horizon Fitness treadmill running again!

# MAINTENANCE

Cleanliness of your treadmill and its operation environment will keep maintenance problems and service calls to a minimum. For this reason, we recommend that the following preventive maintenance schedule be followed.

## AFTER EACH USE (DAILY)

Clean and inspect, following these steps:

- Turn off the treadmill with the on/off switch, then unplug the power cord at the wall outlet.
- Wipe down the running belt, deck, motor cover, and console casing with a damp cloth. Never use solvents, as they can cause damage to the treadmill.
- Inspect the power cord. If the power cord is damaged, contact Horizon Fitness.
- Make sure the power cord is not underneath the treadmill or in any other area where it can become pinched or cut.
- Check the tension and alignment of the running belt. Make sure that the treadmill belt will not damage any other components on the treadmill by being misaligned.

## EVERY WEEK

Clean underneath the treadmill, following these steps:

- Turn off the treadmill with the on/off switch, then unplug the power cord at the wall outlet.
- Fold the treadmill into the upright position, making sure that the lock latch is secure.
- Move the treadmill to a remote location.
- Wipe or vacuum any dust particles or other objects that may have accumulated underneath the treadmill.
- Return the treadmill to its previous position.

## EVERY MONTH - IMPORTANT!

- Turn off the treadmill with the on/off switch, then unplug the power cord at the wall outlet.
- Inspect all assembly bolts of the machine for proper tightness.
- Turn off the treadmill and wait 60 seconds.
- Remove the motor cover. Wait until ALL display screens turn off.
- Clean the motor and lower board area to eliminate any lint or dust particles that may have accumulated. Failure to do so may result in premature failure of key electrical components.
- Vacuum and wipe down the belt with a damp cloth. Vacuum any black/white particles that may accumulate around the unit. These particles may accumulate from normal treadmill use.

## EVERY 6 MONTHS OR 150 MILES

It is necessary to lubricate your treadmill running deck every six months or 150 miles to maintain optimal performance. Once the treadmill reaches 150 miles, the console will display the message "LUBE" or "LUBE BELT". The treadmill will not operate while the message is showing. Hold Stop for 5 seconds to suspend message for 5 miles. Your treadmill came with a bottle of lubricant which can be used for two applications. If you need lubricant contact Horizon Fitness. Only use lubricant provided by Horizon Fitness.

- Turn off the treadmill with the on/off switch, then unplug the power cord at the wall outlet.
- Loosen both the rear roller bolts. (For best results, place two removable marks on both sides of the frame and note roller position). Once the belt is loosened, take the bottle of lubricant and apply it to the entire top surface of the running deck. Tighten both rear roller bolts (matching up the marks for proper position) to original position. After you have applied lubricant, plug in the power cord, insert the safety key, start the treadmill and walk on the belt for two minutes to spread the lubricant.
- Lubricate the air shocks with Teflon based spray.
- Once lubrication is complete, reset the console by pressing and holding 'STOP' and Speed '+' buttons for 5 seconds.

## LUBRICATION

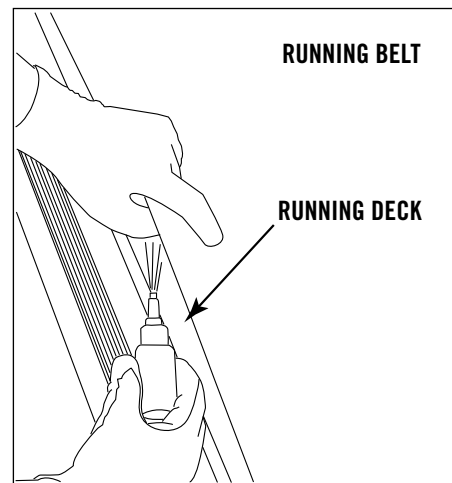

Please contact Horizon Fitness with questions about applying lubricant to your treadmill.



# LIMITED HOME-USE WARRANTY

**Weight Capacity = 300 LBS**

## **FRAME • LIFETIME**

Horizon Fitness warrants the frame against defects in workmanship and materials for the lifetime of the original owner, so long as the device remains in the possession of the original owner. (The frame is defined as the welded metal base of the unit and does not include any parts that can be removed.)

## **MOTOR • LIFETIME**

Horizon Fitness warrants the motor against defects in workmanship and materials for the lifetime of the original owner, so long as the device remains in the possession of the original owner.

## **ELECTRONICS & PARTS • 1 YEAR**

Horizon Fitness warrants the electronic components, finish and all original parts for a period of one year from the date of original purchase, so long as the device remains in the possession of the original owner.

## **LABOR • 1 YEAR**

Horizon Fitness shall cover the labor cost for the repair of the device for a period of one year from the date of the original purchase, so long as the device remains in the possession of the original owner.

## **EXCLUSIONS AND LIMITATIONS**

Who IS covered:

- The original owner and is not transferable.

What IS covered:

- Repair or replacement of a defective motor, electronic component, or defective part and is the sole remedy of the warranty.

What IS NOT covered:

- Normal wear and tear, improper assembly or maintenance, or installation of parts or accessories not originally intended or compatible with the equipment as sold.
- Damage or failure due to accident, abuse, corrosion, discoloration of paint or plastic, neglect, theft, vandalism, fire, flood, wind, lightning, freezing, or other natural disasters of any kind, power reduction, fluctuation or failure from whatever cause, unusual atmospheric conditions, collision, introduction of foreign objects into the covered unit, or modifications that are unauthorized or not recommended by Horizon Fitness.
- Incidental or consequential damages. Horizon Fitness is not responsible or liable for indirect, special or consequential damages, economic loss, loss of property, or profits, loss of enjoyment or use, or other consequential damages of whatsoever nature in connection with the purchase, use, repair or maintenance of the equipment.
- Equipment used for commercial purposes or any use other than a single family or Household, unless endorsed by Horizon Fitness for coverage.
- Equipment owned or operated outside the US and Canada.
- Delivery, assembly, installation, setup for original or replacement units or labor or other costs associated with removal or replacement of the covered unit.
- Any attempt to repair this equipment creates a risk of injury. Horizon Fitness is not responsible or liable for any damage, loss or liability arising from any personal injury incurred during the course of, or as a result of any repair or attempted repair of your fitness equipment by other than an authorized service technician. All repairs attempted by you on your fitness equipment are undertaken AT YOUR OWN RISK and Horizon Fitness shall have no liability for any injury to the person or property arising from such repairs.

## **SERVICE/RETURNS**

- In-home service is available within 150 miles of the nearest authorized repair center (Mileage beyond 150 miles from an authorized service center is the responsibility of the consumer).
- All returns must be pre-authorized by Horizon Fitness.
- Horizon Fitness' obligation under this warranty is limited to replacing or repairing, at Horizon Fitness' option, the same or comparable model at one of its authorized service centers.
- A Horizon Fitness authorized service center must receive all equipment for which a warranty claim is made. This equipment must be received with all freight and other transportation charges prepaid, accompanied by sufficient proof of purchase.
- Replacement units, parts and electronic components reconditioned to As-new Condition by Horizon Fitness or its vendors may sometimes be supplied as warranty replacement and constitute fulfillment of warranty terms.
- This warranty gives you specific legal rights, and your rights may vary from state to state.

## ***CUSTOMER TECH SUPPORT***

*For fast and friendly service, please contact one of our trained customer technicians via phone, email or our website.*

*Customer Tech Support Hotline: 1-800-244-4192*

*Email: [comments@horizonfitness.com](mailto:comments@horizonfitness.com)*

*Website: [www.horizonfitness.com](http://www.horizonfitness.com)*

*Every employee at Horizon Fitness takes pride in providing you with a high quality product. We want to know if you have a problem and we want to have an opportunity to correct it for you.*

***NOTE:*** *Please read the TROUBLESHOOTING section before contacting Customer Tech Support. To receive additional product information, visit us at [www.horizonfitness.com](http://www.horizonfitness.com)*



***HORIZON***  
*FITNESS*

**1620 Landmark Drive,  
Cottage Grove WI, 53527  
Tel: 1.800.244.4192  
Fax: 608.839.1260**